

MINISTRY OF EDUCATION AND SCIENCE OF UKRAINE
TARAS SHEVCHENKO NATIONAL UNIVERSITY OF KYIV

PHYSICS

Electricity and Magnetism, Optics, Atomic and Nuclear Physics

Textbook



УДК 53+537+535+539.18+539.1](075.8)
P59

Reviewers:

Full Member of NAS of Ukraine, Dr. of Sci., Prof. O. Kordyuk
(*Kyiv Academic University of NAS of Ukraine*);

Dr. of Sci., Ass. Prof. O. Makarenko
(*Taras Shevchenko National University of Kyiv*)

*Recommended for publication
by Academic Council of Faculty of Physics
(Protocol № 10 dated 28 Desember 2021)*

*Adopted by the Scientific and Methodological Council
of Taras Shevchenko National University of Kyiv
(Protocol № 3-22 dated 14 April 2022)*

P59 Physics. Electricity and Magnetism, Optics, Atomic and Nuclear Physics : textbook / O. O. Kalenyk, I. V. Plyushchay, T. L. Tsaregradska, P. O. Lishchuk. – K. : Publishing and Polygraphic Center "Kyiv University", 2022. – 110 p.

The textbook contributes to the study of the fundamentals of physics course, as well as deepens knowledge and understanding of phenomena and laws of nature, which are necessary for students to study physics in institutions of higher education of medical and biological profile. The structure and contents of the textbook correspond to the program of physics at preparatory departments for foreign students. The textbook contains necessary vocabulary and the constructs of scientific language for adapted perception of lectures and practical lessons of physics in English by foreign students.

For foreign students of the preparatory departments.

UDC 53+537+535+539.18+539.1](075.8)

© Kalenyk O. O., Plyushchay I. V., Tsaregradska T. L., Lishchuk P.O., 2022
© Taras Shevchenko National University of Kyiv,
Publishing and Polygraphic Centre "Kyiv University", 2022

PREFACE

According to the structure and content, this textbook corresponds to the course of physics at the preparatory departments for foreign students of higher educational institutions of Ukraine. Specification of goals and tasks of teaching physics is presented taking into account the specific features of the system of teaching foreign students.

The textbook provides the necessary amount of information that ensures mastery of basics of electricity, magnetism, optics, atomic and nuclear physics by foreign students (part II¹). For better training of foreign students, the textbook is adapted according to the program of studying English language at preparatory departments. All topics in the textbook are constructed as follows: text – basic concepts, lexical and grammar material – new words and terms; examples of constructs of scientific style of speech; exercises and tasks with a solution, questions and tasks for independent work. Illustrations – drawings, graphs and general tables of basic physical quantities will also help in training process.

There is a terminology table presented at the end of each topic. There is a glossary containing definitions of all of the key terms used at the end of every module or chapter.

¹ See part I in: Kozachenko V. V., Kalenyk O. O., Tsaregradska T. L. Physics. Mechanics, Molecular Physics and Thermodynamics. K., 2019.

SECTION I

ELECTRICITY AND MAGNETISM.

OPTICS

CHAPTER 1

Electricity

§ 1. Electrical charge. Coulomb's law

1. Electric charges

In nature, there is another type of interaction between physical bodies, in addition to gravitational interaction. This interaction is called **electromagnetic**, it occurs between the bodies that have an electric charge.

An electric charge is a physical quantity that characterizes the property of a body or particle to enter into an electromagnetic interaction. Electric charge is a fundamental property of matter.

Electricity¹ studies the phenomena of nature, associated with the presence and motion of matter that has a property of electric charge. The branch of physics that studies electromagnetic interaction is called **electrodynamics**. Electrodynamics covers electricity, magnetism and studies the properties of electromagnetic waves. The branch of electrodynamics that studies only stationary electric charges is called **electrostatics**.

¹ The word "electricity" comes from Greek. The word "electron", which means amber-hardened pine resin, which can attract small objects after rubbing it with a cloth.

In nature, there are two types of electric charges: **positive** and **negative**. Electric charges interact via the forces of repulsion and attraction. The charges of one sign are repelled, and the charges of different signs are attracted. The electric charge is denoted by the letter q . Carriers of electric charges are some elementary particles. For example, a hydrogen atom H consists of one proton (nucleus) and one electron orbiting the nucleus. **Protons** and **electrons** are elementary particles. A proton has a positive charge and an electron has a negative charge. However, the hydrogen atom is electrically neutral, i. e. its total electric charge is zero. The electric charge of a proton and an electron is called an **elementary charge**. The electric charge of an electron and a proton is equal in absolute value

$$|e| = 1.6 \cdot 10^{-19} \text{ C}.$$

The unit of electric charge in the SI system – **coulomb**¹ (C).

The law of conservation of electric charge: in an isolated system at any interactions of bodies the algebraic sum n of the electric charges of all bodies (the net charge) remains constant

$$\sum_{i=1}^n q_i = \text{const}.$$

The body that allows the flow of charge in one or more directions is called **conductor**. Conductors include all metals, graphite, aqueous solutions of salts (i. e., ionic compounds dissolved in water), acids, and the human body.

Dielectrics, or insulators, are bodies in which electric charges cannot move freely. Dielectrics include plastic, glass, ebonite, silk, and wood.

Semiconductors are the bodies that have the properties of **conductors** or **dielectrics**, depending on the conditions. Common dielectrics include germanium, silicon, some alloys and chemical compounds. Semiconductors can be found in thousands of modern products such as computers, smartphones, gaming hardware, and medical equipment.

¹ Charles Coulomb (1736–1806) – a French physicist, military engineer, who established the basic law of electrostatics.

2. Coulomb's law

An electric field – is a field that exists around electric charges. The field of stationary charges is called the **electrostatic field**. Consider the model of a point charge. A **point charge** is a charged body whose size is small compared to the distance between them and can be neglected.

Coulomb's law: the forces of interaction \vec{F}_{12} , \vec{F}_{21} of two stationary point charges q_1 i q_2 , located at a distance r in a liquid or gas, are proportional to the product of these charges, inversely proportional to the square of the distance between them and directed along the line connecting these charges (Fig. 1.1):

$$F_{12} = F_{21} = \frac{1}{4\pi\epsilon\epsilon_0} \cdot \frac{q_1 \cdot q_2}{r^2},$$

where $\epsilon_0 = 8.85 \cdot 10^{-12} \text{ C}^2 / (\text{N} \cdot \text{m}^2)$ – electric constant; ϵ – dielectric constant of the substance.

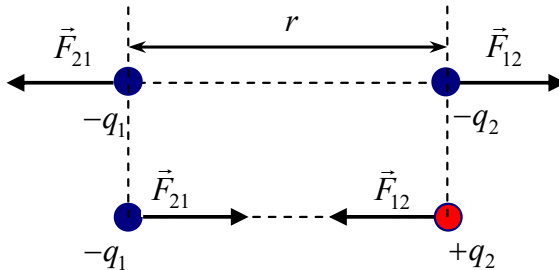

Fig. 1.1

Dielectric constant (or relative permittivity) is a characteristic of a substance that shows how many times the force of interaction of charges in a given medium is less than in a vacuum. It is a dimensionless quantity and always $\epsilon \geq 1$. In a vacuum $\epsilon = 1$.

An important characteristic of the electric charge on the surface of the body is **the surface charge density**. This parameter is important

for the characterization of bodies with shape and size that cannot be neglected. The surface charge density of a uniformly charged conductor is equal to the ratio of charge to the area of the conductor

$$\sigma = \frac{q}{S}.$$

Problem. Two metal balls with a diameter $d = 5$ cm immersed in transformer oil ($\varepsilon = 2.2$). The distance between the centers of the balls $r = 0.5$ m. Determine the surface charge density on the balls if they interact with the force $F = 2.2 \cdot 10^{-3}$ N.

Given:

$$d = 5 \text{ cm} = 0.05 \text{ m}$$

$$r = 0.5 \text{ m}$$

$$F = 2.2 \cdot 10^{-3} \text{ N}$$

$$\varepsilon = 2.2$$

Find σ – ?

Solution. Surface charge density on a sphere $\sigma = \frac{q}{S}$, where

$$S = 4\pi R^2 = \pi d^2 \text{ – the surface area of the sphere with radius } R = \frac{d}{2}.$$

The magnitude of the charge is determined by Coulomb's law:

$$F = \frac{1}{4\pi\varepsilon_0\varepsilon} \cdot \frac{q^2}{r^2} \Rightarrow q = \sqrt{4\pi\varepsilon_0\varepsilon F} \cdot r.$$

Substituting the values q and S in the equation of the surface charge density, we can find its exact value

$$\sigma = \frac{\sqrt{4\pi\varepsilon_0\varepsilon F} \cdot r}{\pi d^2} \approx 4.7 \cdot 10^{-5} \text{ C/m}^2.$$

Answer: $\sigma \approx 4.7 \cdot 10^{-5} \text{ C/m}^2$.

Words and phrases

positive charge	elementary charge	electric constant	conductor
negative charge	Coulomb's law	permittivity	semiconductor
electric field	surface density of charge	insulator	dielectric

Tasks for independent work

I. Answer the questions

1. What kind of interaction exists between charged bodies?
2. What types of charges exist in nature?
3. What is an elementary charge?
4. What charges are called point charges?
5. In what units is the electric charge measured?
6. Why is the strength of the interaction between charges?
7. What is the physical nature of the relative dielectric constant of the dielectric?
8. What is the difference between a conductor, a dielectric and a semiconductor?
9. How to find the surface charge density of a body?

II. Solve the problems

1. Write down and formulate the law of conservation of charge.
2. Write down and formulate Coulomb's law.
3. Two identical positive charges are located at a distance of 3 cm from each other and are repelled in water with force $F = 1.6 \cdot 10^{-4}$ N. Determine the magnitude of each charge ($\epsilon_{\text{H}_2\text{O}} = 81$).
4. The same small metal balls bearing the same charges of 15 nC and 60 nC are located at a distance of 2 m from each other. The balls touched each other, and then they were separated by some distance (charges were added and divided equally). How far should they be spaced so that the strength of the interaction does not change?
5. Two spheres have masses of 10 g. What are the same charges that must be given to these spheres so that the Coulomb repulsion evenly weighs the gravitational pull? The distance between the balls is large compared to their radii.

6. Two identical balls, each of mass m , are suspended at one point on threads of length l . The balls have the same charges. The angle between the threads is 2α . Determine the charges of the balls.

Remember!

1. Electrodynamics covers electricity, magnetism and studies the properties of electromagnetic waves.
2. The proton has a positive charge, and the electron has a negative charge.

§ 2. Main characteristics of electric field

1. Electric field strength

Each electric charge creates an electric field that acts only on electric charges. The forces of action of an electric field on a charge are called **electric forces**. The electric field, which is created by a charge, propagates from that charge to infinity. The electric field is studied using a test charge – a single positive point charge $q_0 = +1$.

The region around the electric charge in which the stress or electric force acts is called the **electric field strength** (the **electric field intensity**, or simply **the electric field**). The electric field strength is a **force characteristic** of the electric field. The magnitude and direction of the electric field have expressed the value of \vec{E} . The electric field strength at a given point – it is a physical vector quantity equal to the ratio of the electric force \vec{F} with which the field acts on the test charge q_0 placed at this point of the field:

$$\vec{E} = \frac{\vec{F}}{q_0}.$$

The direction of the stress vector \vec{E} coincides with the direction of the force \vec{F} . The unit of the electric field \vec{E} in the SI system is **Newton per coulomb** [N/C].

If you substitute in the equation $\vec{E} = \frac{\vec{F}}{q_0}$ the expression of force from Coulomb's law, you can get a formula for determining the intensity around a point charge:

$$F_{12} = F_{21} = \frac{1}{4\pi\epsilon\epsilon_0} \cdot \frac{q \cdot q_0}{r^2},$$

$$E = \frac{F}{q_0} = \frac{1}{q_0} \cdot \frac{1}{4\pi\epsilon\epsilon_0} \cdot \frac{q \cdot q_0}{r^2} = \frac{1}{4\pi\epsilon\epsilon_0} \cdot \frac{q}{r^2},$$

where q – is a point charge that creates a field; r – the distance from the charge to the point where the intensity is determined. For the direction of the vector \vec{E} we take the direction of force \vec{F} , which acts on an elementary positive charge q_0 , located at this point in the field. Let's find the electric field at the point A , which is the sum of electric fields of charges $-q_1$ and $+q_2$, namely: $\vec{E} = \vec{E}_1 + \vec{E}_2$ (Fig. 1.2).

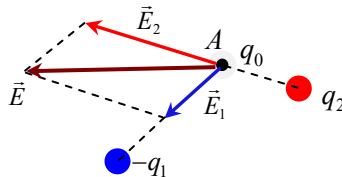

Fig. 1.2

The principle of superposition for electric fields states that every charge in space creates an electric field at a point independent of the presence of other charges in that medium. The resultant electric field is a vector sum of the n electric fields \vec{E}_i due to individual charges

$$\vec{E} = \sum_{i=1}^n \vec{E}_i,$$

2. Electric field lines

Electric fields are graphically represented by force lines. **The force line** of an electric field is called an imaginary line tangent to which at each point coincides with the electric field strength vector \vec{E} (Fig. 1.3).

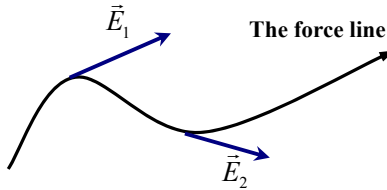

Fig. 1.3

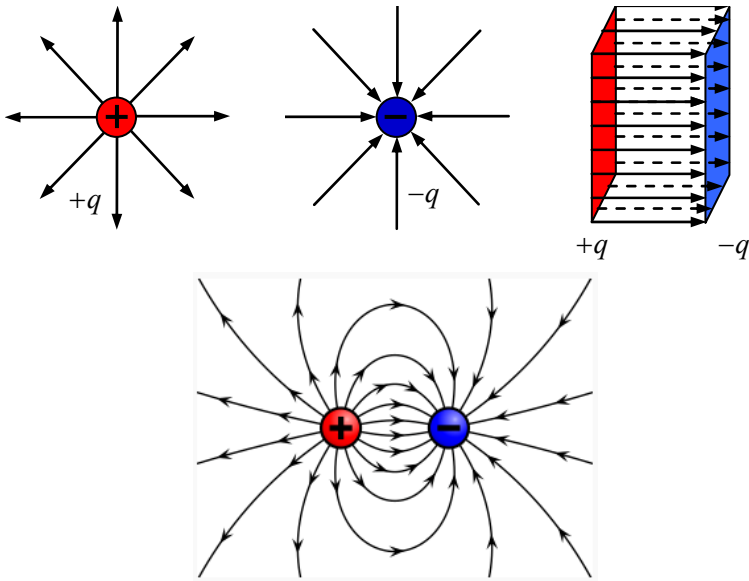

Fig. 1.4

For the positive charge, the line of force comes out of the charge and for the negative charge the line of force will move towards the charge. If the positive and negative charges are located at a great distance from each other, then the field lines go to infinity (Fig. 1.4).

3. Potential. Potential difference

Let's consider a stationary positive charge Q that creates an electric field. Under the action of an electric field, the test charge q_0 will move away from the charge Q to infinity. It is believed that at an infinite distance from the charge there are no other charges and the electric field strength is zero. In practice, the Earth's surface is taken as the beginning of the count, i. e. the point at which there is no electric field from other charges.

When moving the test charge q_0 to the Earth's surface, the electric field of the charge Q performs the work (Fig. 1.5).

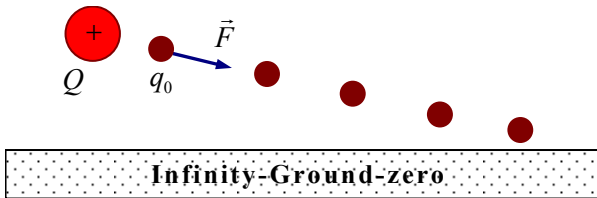

Fig. 1.5

The electric field potential is a scalar physical quantity equal to the ratio of the work performed by the electric forces when moving a positive point charge q_0 from a given point of the field to infinity, to the magnitude of this charge

$$\varphi = \frac{A}{q_0},$$

where φ – is a potential; A – is a work of electric forces. The unit of measurement of potential in the system SI – **volt**¹ (V); $1 \text{ V} = \frac{1 \text{ J}}{1 \text{ C}}$.

The field potential at a distance r from the charge is calculated from the expression

¹ Alessandro Volta (1745–1827) – Italian physicist, who created the first electric battery (in 1800). A unit of measurement of potential and voltage is named in his honour.

$$\varphi = \frac{q}{4\pi\epsilon_0\epsilon r},$$

where q – charge that forms an electric field; r – the distance from the charge to the point where the potential is determined. According to this equation, you can find the potential on the surface of a sphere of radius R , which contains a charge q .

Let the field potential at a point A is equal to φ_1 , and the potential at the point B is equal to φ_2 . You can find the potential difference $\varphi_1 - \varphi_2$ between two points of the field:

$$\varphi_1 - \varphi_2 = \frac{A_1}{q_0} - \frac{A_2}{q_0} = \frac{A_1 - A_2}{q_0},$$

$$\varphi_1 - \varphi_2 = \frac{A_{12}}{q_0}.$$

The potential difference is called **voltage** and denoted by the letter U : $\varphi_1 - \varphi_2 = U$. If $q_0 = +1$, then $\varphi_1 - \varphi_2 = A_{12}$. The difference in the potentials of two points of the electric field is equal to the work of electric forces when moving a single positive charge from one point of the field to another one. The unit of voltage in the SI system is volts (V); $1 \text{ V} = \frac{1 \text{ J}}{1 \text{ C}}$.

4. Potential energy of the electrostatic field

Let the charge q under the action of an electric field move from a point with a potential φ_1 to a point with a potential φ_2 , where $\varphi_1 > \varphi_2$. The work of moving the charge q in an electric field is equal to $A = q(\varphi_1 - \varphi_2)$. According to the law of conservation and conversion of energy for a stationary case, the magnitude of this work does not depend on the shape and length of the trajectory and is a constant value.

The work of electrostatic forces is equal to the product of the charge and the potential difference at the start and endpoints of the path.

Consequence. The work of electrostatic forces when moving the charge in a closed trajectory is *zero*. Let us denote the potential energy of the positive charge q_0 of the electric field by a letter W_p to distinguish it from the notation of the electric field strength \vec{E} . Then the change in potential energy when shifting the position of the charge is equal to the work of electrostatic forces:

$$A = \Delta W_p = W_{p2} - W_{p1} = q_0(\varphi_1 - \varphi_2) = -q_0(\varphi_2 - \varphi_1);$$

$$W_{p2} - W_{p1} = -(q_0\varphi_2 - q_0\varphi_1) = -q_0\Delta\varphi.$$

From the last expression, it is seen that the value $q_0\varphi$ has the dimension of energy (work) – **joules (J)**. A minus sign means that the potential energy W_p decreases with decreasing potential $\varphi_2 < \varphi_1$.

The potential energy of a charge W_p at a point of the field created by another point charge q is equal to the product of this charge to the potential at this point:

$$W_p = q_0\varphi = q_0 \cdot \frac{q}{4\pi\epsilon\epsilon_0 r}.$$

Potential is **an energy characteristic** of an electric field. Let's consider a homogeneous field with electric field strength \vec{E} between uniformly charged plates at a distance d from each other (Fig. 1.6).

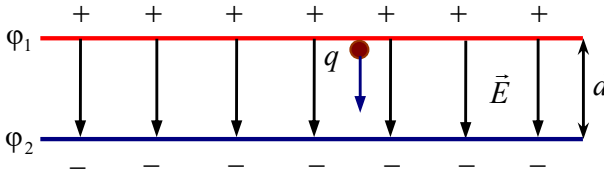

Fig. 1.6

Let the positive charge q moves from one plate to another. The work of the electric field to move the charge is equal to $A = q(\varphi_1 - \varphi_2)$. On the other hand, this work is equal $A = F \cdot d = E \cdot q \cdot d$. Finally, we get $q(\varphi_1 - \varphi_2) = E \cdot q \cdot d$.

From here

$$E = \frac{\varphi_1 - \varphi_2}{d}, \text{ or } E = -\frac{\varphi_2 - \varphi_1}{d} = -\frac{\Delta\varphi}{d}.$$

The intensity of a homogeneous electric field is equal to the potential change per unit length of the power line. The minus sign shows that the field strength vector is always directed in the direction of decreasing potential.

According to the principle of superposition, the electric field formed by several charges has potential at this point of the field, which is equal to the algebraic sum of the potentials φ_i of each charge:

$$\varphi = \sum_{i=1}^n \varphi_i ,$$

where n – the number of electric charges.

The electric field potential is represented in the form of lines. Lines of equal potential are called **equipotential lines**, or **equipotential surfaces** (when we consider a three-dimensional space). Equipotential surfaces are perpendicular to the **force lines** (Fig. 1.7).

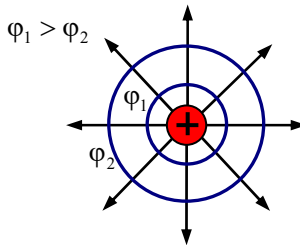

Fig. 1.7

Problem 1. Two point charges $q_1 = 0.67 \cdot 10^{-8} \text{ C}$ and $q_2 = 1.33 \cdot 10^{-8} \text{ C}$ are located at a distance of 40 cm from each other in a vacuum (Fig. 1.8). What work needs to be done to bring the charges to a distance of 25 cm between them?

Given:

$$q_1 = 0.67 \cdot 10^{-8} \text{ C}$$

$$q_2 = 1.33 \cdot 10^{-8} \text{ C}$$

$$r_1 = 0.4 \text{ m}$$

$$r_2 = 0.25 \text{ m}$$

Find: $A = ?$

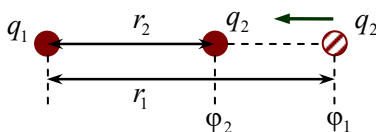

Fig. 1.8

Solution. Let the charge q_1 forms a field and the charge q_2 move in this field from point r_1 to point r_2 . The work of moving the charge q_2 is equal to $A = q_2(\phi_2 - \phi_1)$, where ϕ_1 and ϕ_2 – the potentials of the start and endpoints of the field. The potentials of these points are

$$\phi_1 = \frac{1}{4\pi\epsilon_0} \cdot \frac{q_1}{r_1} \quad \text{and} \quad \phi_2 = \frac{1}{4\pi\epsilon_0} \cdot \frac{q_1}{r_2}, \text{ respectively.}$$

If we substitute values ϕ_1 and ϕ_2 into the expression for work:

$$A = q_2(\phi_2 - \phi_1) = q_2 \left(\frac{1}{4\pi\epsilon_0} \cdot \frac{q_1}{r_2} - \frac{1}{4\pi\epsilon_0} \cdot \frac{q_1}{r_1} \right) = \frac{q_1 q_2}{4\pi\epsilon_0} \left(\frac{1}{r_2} - \frac{1}{r_1} \right),$$

$$A = \frac{0.67 \cdot 10^{-8} \text{ C} \cdot 1.33 \cdot 10^{-8} \text{ C}}{4 \cdot 3.14 \cdot 8.85 \cdot 10^{-12} \frac{\text{C}^2}{\text{N} \cdot \text{m}^2}} \left(\frac{1}{0.25 \text{ m}} - \frac{1}{0.4 \text{ m}} \right).$$

Answer: $A = 1.2 \cdot 10^{-5} \text{ J}$.

Problem 2. Through what potential difference must an electron pass to increase its velocity from $V_1 = 1.0 \cdot 10^7 \text{ m/s}$ to $V_2 = 3.0 \cdot 10^7 \text{ m/s}$. The mass of the electron is equal to $m_e = 9.1 \cdot 10^{-31} \text{ kg}$.

Given:

$$V_1 = 1.0 \cdot 10^7 \text{ m/s}$$

$$V_2 = 3.0 \cdot 10^7 \text{ m/s}$$

$$m_e = 9.1 \cdot 10^{-31} \text{ kg}$$

$$e = -1.6 \cdot 10^{-19} \text{ C}$$

Find: $\phi_1 - \phi_2 = ?$

Solution. According to the law of conservation of energy, work is equal to the change of energy of the system $\Delta E = -A$. The kinetic energy change of the electron when it moves through a potential difference is equal to

$$\Delta E_k = E_{k2} - E_{k1} = \frac{mV_2^2}{2} - \frac{mV_1^2}{2}.$$

In the general case, a change in potential energy when the charge is shifting its position on the electric field

$$\Delta E_p = E_{p2} - E_{p1} = e \cdot \varphi_2 - e \cdot \varphi_1 = e \cdot (\varphi_2 - \varphi_1).$$

According to the law of conservation of energy

$$\Delta E_k + \Delta E_p = \frac{mV_2^2}{2} - \frac{mV_1^2}{2} + e \cdot (\varphi_2 - \varphi_1) = 0.$$

From here

$$\frac{mV_2^2}{2} - \frac{mV_1^2}{2} = e \cdot (\varphi_1 - \varphi_2),$$

$$\begin{aligned} \varphi_1 - \varphi_2 &= \frac{m}{2e} \cdot (V_2^2 - V_1^2) = \\ &= \frac{9.1 \cdot 10^{-31} \text{ kg}}{2 \cdot (-1.6 \cdot 10^{-19}) \text{ C}} \cdot \left(9.0 \cdot 10^{14} \frac{\text{m}^2}{\text{s}^2} - 1.0 \cdot 10^{14} \frac{\text{m}^2}{\text{s}^2} \right) \approx -2275 \text{ V}. \end{aligned}$$

Answer: $\varphi_1 - \varphi_2 \approx -2275 \text{ V}$.

Words and phrases

electrical intensity	potential	power line	voltage
superposition principle	potential difference	Volt	point charge

Tasks for independent work

I. Answer the questions

1. What is the force characteristic of the electric field?
2. What is a force line? From what charges do the power lines begin?

3. What kind of characteristic of an electric field is the potential?
4. What do you mean by potential difference?
5. In what units are the potential and voltage measured?
6. What is the definition of the work of electrical force?
7. Does the magnitude of the work of electric forces depend on the trajectory of the charge in motion?
8. Why does the potential energy of the electric field decrease with increasing distance from the charge that creates this field?

II. Solve the problems

1. The work $A = 4 \text{ J}$ was performed for a motion of charge in the electric field. Determine the magnitude of the charge, if its motion occurred at a voltage of 100 V .

2. In a homogeneous electric field the potential difference between 2 points that are located on the same force line and a distance of 9 cm is equal to 360 V . Find the electric field strength.

3. A ball with a mass 10^{-3} kg has a charge $q = 10^{-8} \text{ C}$ and moves from point A with the potential of 600 B to point B with zero potential. Determine the velocity of the ball at point A if the velocity at point B is 0.2 m/s .

4. A mercury ball with a potential of 1200 V , is broken into 1000 equal drops. Find the potential of each drop.

5. Eight water droplets, each with a radius of 10^{-3} m and a charge of 10^{-10} C coalesce to a single drop. Find its potential.

6. Four point charges are at the corners of a square of side a as shown in Fig. 1.9. Find the magnitude of the electric field strength and potential at point O .

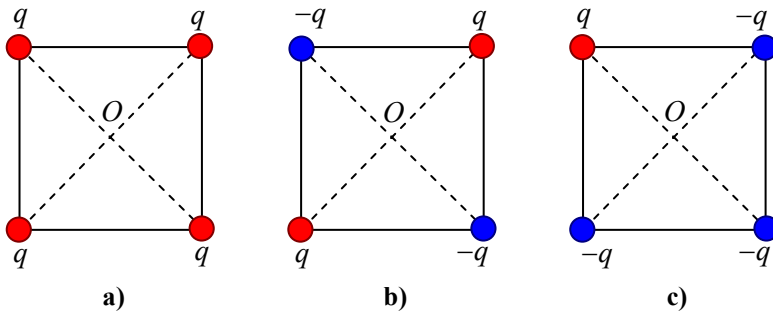

Fig. 1.9

Remember!

1. The electric field acts on the charge.
2. The electric field is studied using a test charge.

§ 3. Electric capacity. Electric field energy

1. Electric capacity

A conductor located far from the other charges is called a **separate conductor**. If we increase the charge by Δq on the separate conductor, its potential will also increase to $\Delta\varphi$. The coefficient of proportionality is denoted as C : $\Delta q = C\Delta\varphi$.

The capacitance of a conductor is a physical quantity equal to the ratio of the magnitude of the charge q of a separate conductor to its potential φ : $C = \frac{q}{\varphi}$. The unit of measurement of capacitance in the SI system is farad¹ [F]:

$$1\text{F} = \frac{1\text{C}}{1\text{V}}.$$

Let's find the capacitance of the conductor, which has the shape of a sphere of radius R and charge q . The surface potential of the sphere is equal to

$$\varphi = \frac{q}{4\pi\varepsilon_0\varepsilon R},$$

and capacitance

$$C = \frac{q}{\varphi} = q \cdot \frac{4\pi\varepsilon_0\varepsilon R}{q} = 4\pi\varepsilon_0\varepsilon R.$$

¹ Michael Faraday (1791–1867) – English physicist, chemist, founder of the theory of the electromagnetic field. A unit of electric capacity is named in his honour.

The capacitance of a separate sphere is directly proportional to its radius and depends on the environment in which it is placed. Let's calculate the capacitance of the planet Earth, which has a spherical shape. The radius of the Earth is approximately equal $R_E = 6400 \text{ km}$. Hence, the electrical capacity of the Earth is equal

$$C_E = 4\pi\epsilon_0\epsilon R_E \approx 3.14 \cdot 1 \cdot 8.85 \cdot 10^{-12} \text{ F/m} \cdot 6.4 \cdot 10^6 \text{ m} \approx 7.0 \cdot 10^{-5} \text{ F}.$$

If the sphere has a capacitance of 1 F, the radius of this sphere should be $R \approx 9.0 \cdot 10^6 \text{ km}$ that is more than the radius of the Earth by 1400 times. 1 F is a very big amount of capacitance. In practice, scientists and engineers use microfarads (μF) – $1 \mu\text{F} = 10^{-6} \text{ F}$ and pico-farads (pF) – $1 \text{ pF} = 10^{-12} \text{ F}$.

2. Capacitor

A capacitor (condenser) is a device that stores electrical energy in an electric field. The capacitor has at least two conductors that have opposite electric charges. These conductors are separated by a non-conductive region (glass, air, paper, plastic, ceramic, etc.)

The system that contains two electrical conductors in the form of flat plates or surfaces separated by a dielectric medium, is called **a flat capacitor** (Fig. 1.10). The capacitor accumulates and holds the charge on the plates. The charges on the capacitor plates have a different sign. The process of transferring charge to the capacitor plate is called **charging the capacitor**.

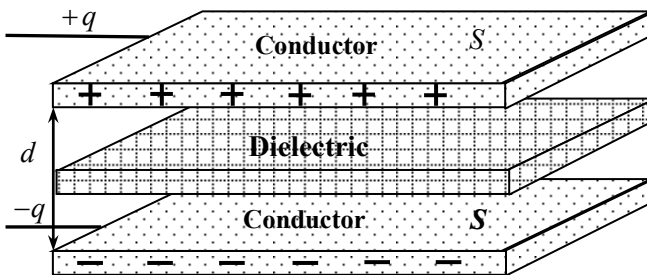

Fig. 1.10

Plates are called **capacitor covers**. To charge, one cover is connected to the positive pole of the electric source and the other one – to the negative pole or can be grounded. The capacitance of capacitor is determined by the equation

$$C = \frac{q}{\varphi_1 - \varphi_2},$$

where $(\varphi_1 - \varphi_2)$ is the potential difference between the covers:

$$C = \frac{\varepsilon_0 \varepsilon S}{d},$$

where S – is the area of each cover; d – is the distance between the covers; ε_0 – electric constant; ε – dielectric constant (or relative permittivity) of the dielectric between the covers.

The capacitance of a flat capacitor, which consists of two plates, is directly proportional to the area of its plates and the relative permittivity of dielectric and inversely proportional to the thickness of the dielectric. Increasing the capacitance of the capacitor is realized by adding capacitor plates. The capacitance of the capacitor, in this case, is found by the equation

$$C = \frac{\varepsilon_0 \varepsilon S}{d}(n-1),$$

where n – is the number of plates.

3. Connection of capacitors

In practical application, the capacitors are connected **in parallel** and **in series**. A system of connected capacitors is called a **battery**. In the schemes and pictures, the capacitor is denoted by the symbol $\left| \right|$. For the parallel connection of capacitors, its plates of the same charge sign should be connected. In this case, the charges of one sign

$q = \frac{C}{\varphi}$ on the covers of the capacitors will be added. The potential of

the connected covers of one sign remains constant (Fig. 1.11). The total charge of the covers is equal to $Q = q_1 + q_2 + \dots + q_n$. If we divide the left and right parts by φ , we obtain

$$\frac{Q}{\varphi} = \frac{q_1}{\varphi} + \frac{q_2}{\varphi} + \dots + \frac{q_n}{\varphi} \Rightarrow C_{\text{total}} = C_1 + C_2 + \dots + C_n.$$

The total battery capacity of capacitors connected in parallel is equal to $C_{\text{total}} = C_1 + C_2 + \dots + C_n$.

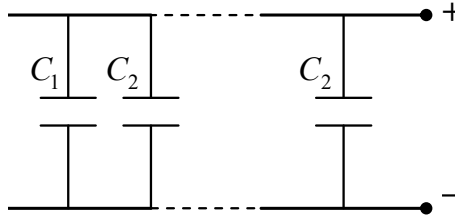

Fig. 1.11

When the capacitors are connected in series, the capacitors' plates with different signs are connected. In this case, the sum potential differences on the covers is equal to the potential difference of the battery $\varphi_1 + \varphi_2 + \dots + \varphi_n = \varphi$, and the charge remains the same (Fig. 1.12):

$$\varphi = \frac{q}{C_{\text{total}}} = \frac{q}{C_1} + \frac{q}{C_2} + \dots + \frac{q}{C_n} \Rightarrow \frac{1}{C_{\text{total}}} = \frac{1}{C_1} + \frac{1}{C_2} + \dots + \frac{1}{C_n},$$

$$\frac{1}{C_{\text{total}}} = \frac{1}{C_1} + \frac{1}{C_2} + \dots + \frac{1}{C_n}.$$

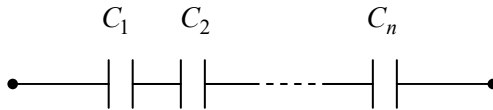

Fig. 1.12

When capacitors are connected in series the total capacity of the battery is always less than the smallest capacitor capacity in this battery. Therefore, this type of connection is used to reduce the total capacity of the battery. The mixed connection of capacitors consists of both series and parallel connections.

4. Electric field energy

Any charged conductor receives energy during its charging. When discharged, the conductor gives off this energy. The energy of the capacitor is equal to the work that must be done to increase the potential difference on the covers of the capacitor from 0 to φ . It can

be determined by the equation $W = q \cdot \varphi_{av}$, where $\varphi_{av} = \frac{0 + \varphi}{2} = \frac{\varphi}{2}$ is

the average value of the potential, therefore $W = \frac{q \cdot \varphi}{2}$. Given that

$q = C\varphi$, the equation for the energy W of a charged capacitor can be written as follows

$$W = \frac{C \cdot \varphi^2}{2},$$

where C – is the capacitance of the conductor; q – its charge; φ – is the potential.

The energy of charged bodies is the energy of an electric field generated by electric charges. Therefore, this type of energy is called **electric field energy**. For example, in a flat capacitor, the energy of the electric field is concentrated in the space between its covers.

Problem. Capacitors with a capacity of $2 \mu\text{F}$ and $8 \mu\text{F}$ are connected in series to a voltage source of 200 V . Determine the potential difference on each capacitor and the energy of each capacitor.

Solution. In the series connection of capacitors, the charges on the capacitors will be the same $q_1 = q_2 = q$; $\varphi_1 + \varphi_2 = U$. The potential

difference on capacitors $U_1 = \frac{q}{C_1}$ and $U_2 = \frac{q}{C_2}$, respectively. The

equation of charge $q = CU$. When connected in series

$$\frac{1}{C} = \frac{1}{C_1} + \frac{1}{C_2}, \text{ or } C = \frac{C_1 C_2}{C_1 + C_2},$$

Then $q = \frac{C_1 C_2}{C_1 + C_2} U$:

$$U_1 = \frac{C_2}{C_1 + C_2} U; \quad U_2 = \frac{C_1}{C_1 + C_2} U.$$

$$W_1 = \frac{C_1 \cdot U_1^2}{2}, \quad W_2 = \frac{C_2 \cdot U_2^2}{2}.$$

Answer: $U_1 = 160 \text{ V}$; $U_2 = 40 \text{ V}$;

$W_1 = 2,6 \cdot 10^{-2} \text{ J}$; $W_2 = 6,4 \cdot 10^{-3} \text{ J}$.

Words and phrases

electrical capacity	battery	capacitor	in parallel connection
Farad	grounding	condenser	in series connection
plate	plate capacitor	covers	fields energy

Tasks for independent work

I. Answer the questions

1. What physical quantity is called capacitance?
2. What is the unit of measurement for capacitance?
3. What is a capacitor?
4. How to connect capacitors?
5. What determines the capacitance of the capacitor?
6. Where is the energy of the electric field of a flat capacitor concentrated?

II. Solve the problems

1. The capacitor $C_1 = 3 \mu\text{F}$ is charged to a voltage $U_1 = 300 \text{ V}$, and the capacitor $C_2 = 2 \mu\text{F}$ is charged to a voltage $U_2 = 200 \text{ V}$. After that, the capacitors were connected in parallel. What voltage will be set on the covers after the connection of capacitors?

2. A capacitor of $1 \mu\text{F}$ is connected in series to the capacitors with a capacitance of $2 \mu\text{F}$ and $4 \mu\text{F}$ that are connected in parallel. Determine the capacity of the battery.

3. The ball is immersed in oil ($\varepsilon = 4$) and has a potential of 4500 V. The surface charge density of the ball is $\sigma = 1.13 \cdot 10^{-5} \text{ C/m}^2$. Find the radius, charge, capacity and energy of the sphere.

4. Two capacitors with a capacitance C_1 and C_2 were charged to voltages $U_1 = 300 \text{ V}$ and $U_2 = 100 \text{ V}$, respectively, and then connected in parallel. At the same time, the potential difference between the covers became $U = 250 \text{ V}$. Find the relationship $\frac{C_1}{C_2}$.

Remember!

1. The capacitor accumulates charge.
2. Capacitors are connected in series or parallel.

§ 4. Electric current. Resistance. Ohm's law

1. Electric current. Amperage

Electric current is the ordered motion of electric charges. In metals it is the ordered motion of electrons; in electrolytes – the motion of ions; current in gases – the motion of electrons and ions. The direction of electric current is considered to be the direction of positive charges motion.

Current is a physical quantity equal to the ratio of the charge transferred through a conductor to the time during which the charge is transferred $I = \frac{q}{t}$, where I – is a current, q – is a charge, t – is a

time. Unit of current in the SI system – **amperes**¹ (A): $1 \text{ A} = \frac{1 \text{ C}}{1 \text{ s}}$.

A **direct electric current** is a current whose strength and direction do not change over time. The force of the direct current in a metal conductor with a cross-sectional area S is equal to $I = ne\bar{V}S$,

¹ Andre-Marie Ampere (1775–1836) – a prominent French physicist, researcher of the nature of electromagnetism. A unit of measurement of electric current is named in his honour.

where e – is the absolute value of the electron charge; n – is the concentration of charge carriers; \bar{v} – the average velocity of the ordered motion of electrons.

To create an electric current in a conductor, it should have free charge carriers and a voltage $U = \varphi_1 - \varphi_2$ at the ends of the conductor. As a result, an electric field is created, which will act on the charges and make them move in the conductor. The potential difference, i. e. the electric voltage U , is created by a **source of electrical energy** (for example, by a capacitor). There are a lot of different devices and equipment that convert other types of energy (mechanical, chemical, light, nuclear) into electrical energy.

2. Voltage in the circuit

To maintain the continuous movement of charges along the conductor, the energy of the current source is consumed. The electric current in a conductor performs work that converts the energy of the current source into other types of energy. The ratio of the work A performed to move the charge q along the section of the electrical circuit to the module of this charge is determined by the voltage U of the section of the circuit

$$U = \frac{A}{q}.$$

The existence of a voltage U between two points in space (including in a metal conductor) means that there is **an electric field** in this space. To maintain the electric field in the conductor, it is necessary to constantly supply energy from the current source.

The electrical circuit may consist of a current source and measuring instruments. Fig. 1.13 shows an example of an electrical circuit. Each element of the circle has its name and schematic view. The direction of the current is indicated by arrows. Using the notation of Fig. 1.11, we have: 1 – current source (*emf* – electromotive force); 2 – electric lamp; 3 – resistor (passive element of electrical circuit with electrical resistance, see details below on the next subsection); 4 – voltmeter (device for measuring voltage); 5 – ammeter (device for measuring current); 6 – switch, 7 – current direction.

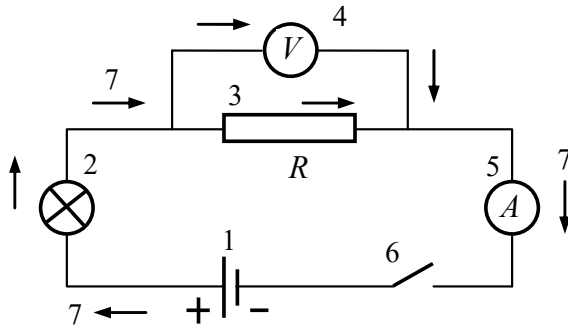

Fig. 1.13

The current in the circuit is measured with an ammeter and the voltage with a voltmeter. The ammeter is connected to the section of the electrical circuit in series and the voltmeter – in parallel connection.

3. Resistance. Ohm's law for a section of electrical circuit

Any conductor can **resist** the directional movement of free charges through it (to be a **resistor**). For example, in metals, the carriers of freely moving charges are electrons. Metal is a solid body that has a crystalline structure. In the nodes of the **crystal lattice**, there are positively charged ions – metal atoms, which are separated by one or more electrons. These electrons move freely, chaotically, and belong to all ions of the structure. Free electrons together are called **electron gas**. A collective electrical interaction between ions and electron gas forms a **metallic bond**. For example, Fig. 1.14 describes an elementary cell of a volume-centric crystal lattice of Fe.

If we apply a potential difference to the conductor, the created electric field acts on free electrons. As the result, they begin to move in a direction, and thus the electric current appears. The interaction of electrons with the ions of the crystal lattice partially prevents the directional motion of electrons. This is the nature of the resistance of the conductor to the electric current inside this structure.

The **electrical resistance** is a physical quantity that characterizes the properties of conductors' opposition to the flow of electric

current. To study the dependence of current on voltage we can construct an electric circuit from a current source, rheostat, ammeter and voltmeter. A **rheostat** is a device that allows you to smoothly change the resistance of the conductor, and hence the current in it.

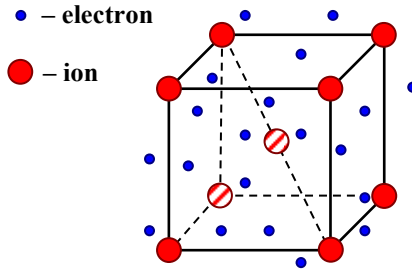

Fig. 1.14

The **resistor box** is a device that allows to change and measure the resistance. It has been experimentally established that the current I in a conductor is directly proportional to the applied voltage U : $I = \sigma \cdot U$, where the coefficient of proportionality σ is called the **conductivity**, or **electrical conductivity** of the conductor. The coefficient of proportionality, which does not depend on the voltage, is equal to $\sigma = \frac{1}{R}$, where R – the resistance of the conductor.

Resistance is inversely proportional to electrical conductivity. The ratio of the voltage in the section of the electric circuit to the current characterizes the resistance of the section, i. e.

$$R = \frac{U}{I}.$$

The Ohm's law for a section of a circuit: the current is directly proportional to the voltage and inversely proportional to the resistance $I = \frac{U}{R}$. The unit of resistance in the SI system is Ohm (Ω)¹; $1\Omega = \frac{1\text{ V}}{1\text{ A}}$.

¹ Georg Ohm (1787–1853) was a German physicist who discovered the law of the dependence of current on voltage. The unit of measurement of electrical resistance is named in his honour.

Ohm's law can be represented graphically (Fig. 1.15): $\operatorname{tg} \alpha = \frac{1}{R} = \sigma$.

This graph is called the volt-ampere characteristic of resistance.

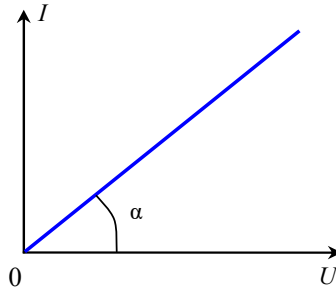

Fig. 1.15

The **resistance of a metal conductor** is directly proportional to the length of the conductor l , inversely proportional to the cross-sectional area S and depends on the material from which the conductor is made

$$R = \frac{\rho \cdot l}{S},$$

where ρ is the **electrical resistivity** (or **specific resistance**). In the SI system, the unit of measurement of electrical resistivity is $\Omega \cdot \text{m}$.

The resistance of metal conductors depends on the temperature (Fig. 1.15 and Table 1.1). This dependence has the form $R = R_0(1 + \alpha \cdot t)$, where R_0 – is a resistance at 0°C ; α – is a **temperature coefficient of resistance**, t – is a temperature in degrees Celsius. The temperature coefficient of resistance is the relative change in resistance of the conductor when heated by one degree.

Table 1.1

The value of the temperature coefficient of electrical resistance α for individual metals						
Metal	Iron, Fe	Tungsten, W	Aluminium, Al	Copper, Cu	Silver, Ag	Platinum, Pt
α, K^{-1}	$6.5 \cdot 10^{-3}$	$4.5 \cdot 10^{-3}$	$4.4 \cdot 10^{-3}$	$4.3 \cdot 10^{-3}$	$4.1 \cdot 10^{-3}$	$3.9 \cdot 10^{-3}$

4. Connection of conductors

In an electrical circuit, the conductors can be connected in series, in parallel or by both these connections. When the conductors are connected in series (Fig. 1.16), the electric current flowing through these conductors will be the same, i. e. the current in all parts of the circuit will be the same $I = I_1 = I_2$. According to Ohm's law on series-connected conductors with different resistances R_1 and R_2 the voltage through these conductors will be different: $U_1 = I \cdot R_1$ and $U_2 = I \cdot R_2$. The total voltage of two conductors is equal to the sum of the voltages $U = U_1 + U_2$.

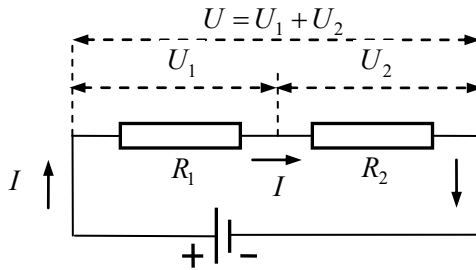

Fig. 1.16

According to Ohm's law $U = I \cdot R$, where R – is the total resistance of two conductors. Then

$$I \cdot R = I \cdot R_1 + I \cdot R_2 ;$$
$$R = R_1 + R_2 .$$

The voltages on each of the conductors are directly proportional to their resistance

$$I = \frac{U_1}{R_1} = \frac{U_2}{R_2} \Rightarrow \frac{U_2}{U_1} = \frac{R_2}{R_1} .$$

We can extend the equality of the total resistance of two conductors to any number of series-connected conductors: for n conductors their total resistance is determined by the expression

$$R = R_1 + R_2 + \dots + R_n .$$

When the conductors are connected in parallel, the voltages on the parallel sections of the circuit are the same (Fig. 1.17). The current in the node of an electric circuit is equal to the sum of the currents in parallel sections $I = I_1 + I_2$. Given Ohm's law, we obtain an expression

$$\frac{U}{R} = \frac{U}{R_1} + \frac{U}{R_2},$$

where

$$\frac{1}{R} = \frac{1}{R_1} + \frac{1}{R_2} \Rightarrow R = \frac{R_1 \cdot R_2}{R_1 + R_2}.$$

Therefore, the inverse of the total resistance is equal to the sum of the inverse of the resistances of the parallel sections.

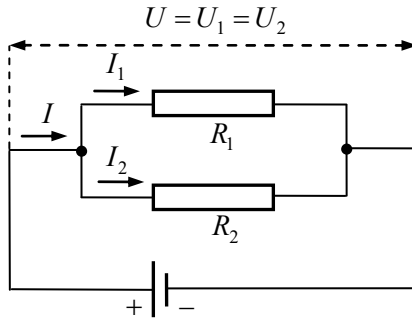

Fig. 1.17

From the equality $U_1 = U_2$ we obtain the ratio between the resistances and the strength of the currents of the parallel sections of the circle

$$\frac{I_1}{I_2} = \frac{R_2}{R_1}.$$

The currents of the parallel sections are inversely proportional to their resistances. In the case of n parallel-connected conductors, their common resistance is determined by the expression

$$\frac{1}{R} = \frac{1}{R_1} + \frac{1}{R_2} + \dots + \frac{1}{R_n}.$$

The total resistance of two metal conductors, which are connected in series or parallel, can be also explained by the electrical resistivity.

The resistance of the conductor with length l is equal to $R = \frac{\rho \cdot l}{S}$.

The length of the conductor l can be divided into two equal parts in two ways $l = l_1 + l_2$ (as a series connection of two conductors) and $S = S_1 + S_2$ (as a parallel connection of two conductors). If $l = l_1 + l_2$,

then these parts have the appropriate resistances $R_1 = \frac{\rho \cdot l_1}{S}$ and

$R_2 = \frac{\rho \cdot l_2}{S}$. Let us distinguish from the expressions for the resistance

of the whole conductor its parts l, l_1, l_2 . Then the following expressions are valid

$$l = \frac{R \cdot S}{\rho}; \quad l_1 = \frac{R_1 \cdot S}{\rho}; \quad l_2 = \frac{R_2 \cdot S}{\rho};$$

$$\frac{R \cdot S}{\rho} = \frac{R_1 \cdot S}{\rho} + \frac{R_2 \cdot S}{\rho} \Rightarrow R = R_1 + R_2.$$

For two pieces of wire connected in parallel, their cross-sectional areas will be added $S = S_1 + S_2$. Let's select the cross-sectional areas and find their sum. This sum will be equal to the total cross-sectional area of two conductors that are connected in parallel

$$S = \frac{\rho \cdot l}{R}; \quad S_1 = \frac{\rho \cdot l}{R_1}; \quad S_2 = \frac{\rho \cdot l}{R_2};$$

$$\frac{\rho \cdot l}{R} = \frac{\rho \cdot l}{R_1} + \frac{\rho \cdot l}{R_2} \Rightarrow \frac{1}{R} = \frac{1}{R_1} + \frac{1}{R_2}.$$

Problem 1. The electric circuit is shown on Fig. 1.18. The voltmeter, which is connected in parallel to the resistor $R_1 = 4 \Omega$, shows $U_1 = 40 \text{ V}$. The voltage of the current source is kept constant and equal to $U = 100 \text{ V}$. Find the ratio of the current flowing through the voltmeter to the current flowing through the resistor with resistance $R_2 = 6 \Omega$.

Given:

$$R_1 = 4 \Omega$$

$$R_2 = 6 \Omega$$

$$U_1 = 40 \text{ V}$$

$$U = 100 \text{ V}$$

Find: $\frac{I_V}{I} - ?$

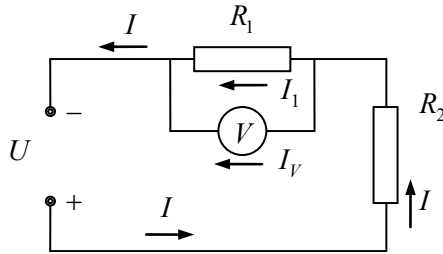

Fig. 1.18

Solution. I_V – the strength of the current flowing through the voltmeter. The voltage across a resistor with resistance R_2 is equal to $U_2 = U - U_1$, and the current flowing through this resistor, according to Ohm's law for the section of the circuit –

$$I = \frac{U_2}{R_2} = \frac{U - U_1}{R_2}.$$

But $I = I_1 + I_V$, where I_1 – current in the resistor R_1 . From her $I_V = I - I_1$. Then

$$\frac{I_V}{I} = 1 - \frac{I_1}{I} = 1 - \frac{\frac{U_1}{R_1}}{\frac{U - U_1}{R_2}} = 1 - \frac{R_2}{R_1} \cdot \frac{U_1}{U - U_1} = 1 - \frac{6}{4} \cdot \frac{30}{100 - 30} \approx 0.36.$$

Answer: $\frac{I_V}{I} \approx 0.36$.

Problem 2. An electric lamp with a tungsten wire at 0°C has a resistance of 300Ω , and when it glows up, the resistance of the wire is 2400Ω . Determine the heating temperature of the wire.

Given:

$$\alpha_w = 4.5 \cdot 10^{-3} \text{ K}^{-1}$$

$$R_0 = 300 \Omega$$

$$R = 2400 \Omega$$

Find: $t - ?$

Solution. The dependence of the resistance of metal conductors on temperature has the form $R = R_0(1 + \alpha \cdot t)$,

$$t = \frac{R - R_0}{\alpha \cdot R_0} = \frac{2400 - 300}{4.5 \cdot 10^{-3} \cdot 300} \approx 1555^\circ \text{C}.$$

Answer: $t \approx 1555^\circ \text{C}$.

Words and phrases

current	direct current (DC)	temperature coefficient of resistance	rheostat
force of current	alternating current (AC)	voltage	current source
resistor	the resistor box	electric circuit	incandescent wire

Tasks for independent work

I. Answer the questions

1. How does current electricity differ from static electricity?
2. What is the definition of electric current?
3. What current is called the direct current?
4. What elements form an electric circuit?
5. How to connect to the part of the electrical circuit ammeter, voltmeter?
6. What is the electrical resistance of a conductor?
7. How to determine the total resistance of an electrical circuit that contains a system of conductors connected in parallel (in series)?

II. Solve the problems

1. Explain how electrical resistance occurs in a metal conductor.
2. Formulate Ohm's law for a section of an electric circuit.
3. Copper wire with a length of 1 km has a resistance of 2.55Ω . Determine the diameter of the wire if the electrical resistivity of copper is equal to $\rho_{\text{Cu}} = 1.75 \cdot 10^{-8} \Omega \cdot \text{m}$.
4. Determine the voltage at the ends of the aluminium wire with a length of 10 m and a diameter of 0.2 mm, through which flows

a current of 70 mA. The specific resistance of aluminium $\rho_{\text{Al}} = 2.82 \cdot 10^{-8} \Omega \cdot \text{m}$.

5. A current of 80 A branches into two conductors with a resistance of 5 Ω and 11 Ω , respectively. Determine the current in each conductor, the voltage across them and the total resistance.

6. Calculate the current flowing through a copper wire with a length of 100 m, and a cross-sectional area of 0.5 mm², if the ends of the wire are at a voltage of 6.8 V. The electrical resistivity of copper is equal to $\rho_{\text{Cu}} = 1.75 \cdot 10^{-8} \Omega \cdot \text{m}$.

7. How many equal parts do you need to cut from a wire with a resistance of 400 Ω to connect its parts in parallel and get a resistance of 4 Ω ?

Remember!

1. The electric current
in the circuit measured by an ammeter.

§ 5. Laws of direct electric current

1. Electromotive force of the current source

Generator – is a current source required to create and maintain an electric current in an electric circuit. Inside the generator, there is the distribution of different charges. The forces that separate the charges in the generator are non-electric in nature, they are called **external forces**. In generators, the work of external forces is performed due to the mechanical energy of water or wind, in accumulators and batteries – due to chemical energy, in photovoltaic cells – due to solar energy.

In a closed-circuit there are external forces of the current source and Coulomb forces in the whole circuit. The work of Coulomb forces in a closed loop is zero. The separation and transfer of charges inside the current source are prohibited by the internal electric field and the resistance of the medium of the current source.

Under the action of external forces \vec{F}_{ext} free charges move from one pole to another (from A to B). When the electric force \vec{F}_{el} is equal to the external force $\vec{F}_{\text{el}} = -\vec{F}_{\text{ext}}$, the work of external forces will stop and the potential difference at the poles of the source will reach a maximum (Fig. 1.19). In a closed circuit, work will be done to move the charge around the circuit due to the energy of external forces (Fig. 1.19). The value determined by the ratio of the work of external forces to the magnitude of the displaced charge inside the source in an open circuit is called the **electromotive force of the source** (*emf*) and is denoted by ε : $\varepsilon = \frac{A_{\text{ext}}}{q}$.

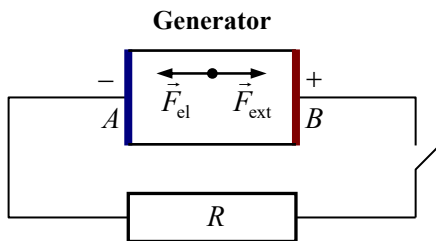

Fig. 1.19

If, $q = 1 \text{ C}$ then $\varepsilon = A_{\text{ext}}$. This means that the *emf* of the source in the SI system is equal to the work of external forces to move the charge of 1 C inside the source in an open circuit, i. e.:

$$\varepsilon = A_{\text{ext}} = q \cdot (\varphi_1 - \varphi_2) = q \cdot U .$$

The voltage at the poles of an open current source is equal to its *emf*.

2. The Ohm's law for a complete (closed) circuit

Consider the simplest complete (closed) circuit. It consists of a source of electromotive force ε , which has an internal resistance r and external resistance R (Fig. 1.20).

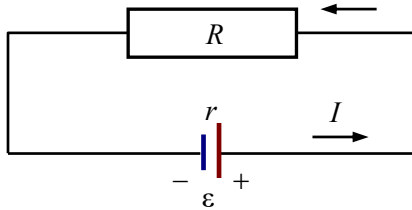

Fig. 1.20

Ohm's law for a full circuit states that the current in a closed circuit is directly proportional to the electromotive force of the current source (*emf*) and inversely proportional to the resistance of the whole circuit

$$I = \frac{\varepsilon}{R + r}.$$

3. The work and power of electric current

Electric energy can be converted into other types of energy. A measure of the electric energy conversion is the work of the electric field forces that moves the charges along the circuit. Let the voltage on the outer part of the circuit be equal U . This means that the work of the electric field of the generator to move the charge of 1 C in this section of the circuit is equal to U . The work of moving the charge q is equal to $A = q \cdot U$, but $q = I \cdot t$, therefore $A = I \cdot U \cdot t$.

The work of direct current in the section of the electric circuit is equal to the product of the voltage at the ends of this section, the current, and the time of its passage. The unit of electric current in the SI system is $1 \text{ J} = 1 \text{ V} \cdot 1 \text{ A} \cdot 1 \text{ s}$. In practice, another unit of work is used: $1 \text{ kW} \cdot \text{h}$ (kilowatt-hour), $1 \text{ kWh} = 3.6 \cdot 10^6 \text{ J}$.

The power of direct current in the section of the electric circuit is equal to the product of the voltage at the ends of this section by the current:

$$P = \frac{A}{t} = I \cdot U.$$

In the SI system, the unit of power is **watts** (W): $1 \text{ W} = 1 \text{ A} \cdot 1 \text{ V}$.

The efficiency of the current source (η) is equal to the ratio of useful work (A_u) to the total work done:

$$\eta = \frac{A_u}{A} = \frac{IUt}{I\varepsilon t} = \frac{U}{\varepsilon} = \frac{IR}{I(R+r)};$$

$$\eta = \frac{R}{(R+r)}.$$

4. Joule–Lenz law

The electric current flowing through the conductor heats it. This process is named **Joule heating**, also known as **resistive, resistance, or Ohmic heating**. The work of electric forces A in a conductor with resistance R , in which current flows I over time t , is equal to the amount of heat released Q in the conductor:

$$Q = A = qU = IUt = I^2Rt = \frac{U^2}{R}t.$$

Joule–Lenz law (also just Joule's law): the amount of heat released in a current-carrying conductor is proportional to the current, voltage, and time of the current passage through the conductor. $Q = IUt$. Joule–Lenz's law establishes a quantitative relationship between the current and heat released in a conductor $Q = I^2Rt$. The release of heat during the current passage in the conductor corresponds to the law of conservation and conversion of energy. Electric charges that have potential energy in the electric field begin to move, and the charges acquire the kinetic energy of motion. While moving, a part of the energy of the charge is transferred to the ions of the crystal lattice. The amplitude of ion oscillations relative to the equilibrium position begins to increase. Thus, the intensity of thermal motion increases, the conductor heats up and its temperature increases.

Problem 1. Two conductors with a resistance of 5Ω and 10Ω , respectively, are connected in parallel and located in an electrical circuit. The heat that is equal to 100 J was released in the

first conductor. How much heat will be released at the same time in the second conductor?

Given:

$$R_1 = 5 \Omega$$

$$R_2 = 10 \Omega$$

$$Q_1 = 100 \text{ J}$$

Find: Q_2 -?

Solution. The amount of heat released in the first conductor during parallel connection is equal to $Q_1 = \frac{U^2}{R_1} t$. The amount of heat released in the second conductor

$$Q_2 = \frac{U^2}{R_2} t .$$

Find the relationship $\frac{Q_1}{Q_2} = \frac{R_2}{R_1}$, here $Q_2 = \frac{R_1}{R_2} Q_1$.

Answer: $Q_2 = 50 \text{ J}$.

Problem 2. A small hydroelectric power plant consumes $V = 240 \text{ m}^3$ of water within 1 minute. The height of the head of water is 4 m. How many electric lamps, which are connected in parallel, can serve this generator if each lamp individually consumes $I_n = 1 \text{ A}$ current with voltage $U = 220 \text{ V}$? The efficiency of the generator $\eta = 75\%$.

Given:

$$V = 240 \text{ m}^3$$

$$t = 60 \text{ s}$$

$$h = 4 \text{ m}$$

$$I_n = 1 \text{ A}$$

$$U = 220 \text{ V}$$

$$\eta = 75\%$$

Find: n - ?

Solution. The electric lamps are connected in parallel, so the total current $I = n \cdot I_n$. A power that is consumed by lamps $P = nI_n U$. The power of the power plant is equal to

$$P = \frac{A \cdot \eta}{t} = \frac{mgh \cdot \eta}{t} = \frac{V\rho gh \cdot \eta}{t},$$

where $A = mgh$ – the work of water falling from h over time $t = 60$ s; m – mass of water; $\rho = 10^3$ kg/m³ – water density;

$g = 9.8$ m/s² – acceleration of free fall. So, $nI_n U = \frac{V\rho gh \cdot \eta}{t}$, where

$$n = \frac{V\rho gh \cdot \eta}{I_n U t} = 535.$$

Answer: 535.

Words and phrases

current source	full circuit	external forces	kilowatt-hour
electromotive force	open circuit	pole	nonelectrical forces
Joule heating	external circuit	generator	internal circuit

Tasks for independent work

I. Answer the questions

1. Why any electric circuit needs a current source?
2. What forces are called external forces?
3. What is called the electromotive force of the current source?
4. Define the work of direct current.
5. Define the power of the direct current.
6. How to explain the thermal effect of electric current?

II. Solve the problems

1. Formulate Ohm's law for a complete circuit.
2. Formulate the Joule–Lenz law.
3. The electric locomotive moves at a speed of 54 km/h and develops a traction force of 68.6 kN. Voltage in the line is 1500 V,

electric motors have the efficiency $\eta = 92\%$. Determine the current in the locomotive motors.

4. Two lamps have the same power. One of them is designed for a voltage of 120 V, and the other one – for 220 V. Determine the ratio of resistances of these lamps.

5. The electric kettle heater has two sections. When the first section is switched on, the kettle boils water during the time t_1 , when the second section is switched on, it can complete the same process during the time t_2 . How long the electric kettle will boil the same amount of water if you turn on two sections: a) in parallel connection; b) in series connection?

Remember!

1. Joule–Lenz's law establishes a quantitative ratio between current and heat.

CHAPTER 2

Magnetism

§ 6. Magnetism. Magnetic induction vector

1. Magnetic phenomena

Magnetic phenomena were first discovered in ancient times when people noticed that lodestones, naturally magnetized pieces of the mineral magnetite (natural magnets) can attract or repel some similar minerals or iron (Fe). Magnetism is a form of interaction of moving electric charges. This interaction occurs through a magnetic field. Stationary electric charges do not create a magnetic field. When the charge begins to move, a magnetic field appears. The magnetic field acts on moving electric charges. The magnetic field transmits the interaction at a speed of 300,000 km/s, i. e. at the speed of light. The magnetic field has energy. Electricity and magnetism are two components of the electromagnetic interaction, forming the electromagnetic field.

Planet Earth has a magnetic field (Fig. 2.1, *a*). There is a hypothesis that the Earth's magnetic field creates a liquid core of our planet, which consists of iron (Fe). The movement of iron ions during the rotation of the planet creates an electric current that generates a magnetic field. There is a phenomenon of aurora borealis (also known as polar lights) at the Earth's poles when charged particles move at high speeds from the Sun in the Earth's magnetic field and interact with the atmosphere. The Earth's magnetic field is a barrier that protects our planet from harmful radiation from the Sun and prevents the solar wind from destroying the atmosphere (Fig. 2.2, *b*).

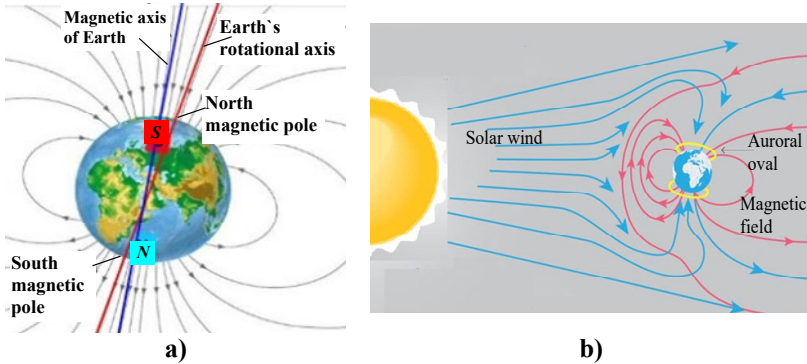

Fig. 2.1

2. The Ampere force

For the first time, a scientist André-Marie Ampère studied the interaction of conductors through which he provided electric current flow. As a result of such interaction, he revealed the presence of the forces of attraction or repulsion between conductors depending on the directions of a current. The force of interaction of two current-carrying conductors is called **the Ampere force** \vec{F}_A (Fig. 2.22).

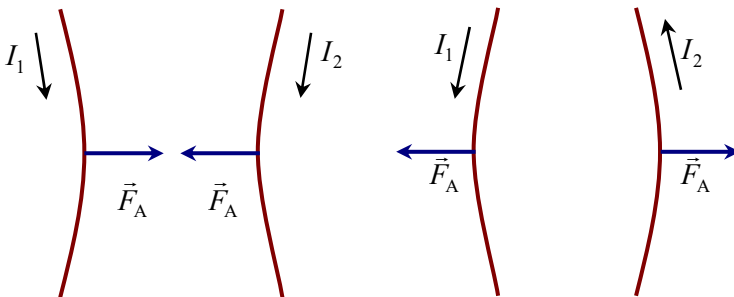

Fig. 2.2

Ampere force occurs since a conductor with a current is exposed to a magnetic field created by another conductor with a current. The interaction of two conductors with current is transmitted through a magnetic field. The Ampere force depends on the magnitude of the

current and the location of the current-carrying conductor in the magnetic field. The Ampere force \vec{F}_A for a linear conductor that has a length is determined by the expression $\vec{F}_A = [I \cdot \vec{l} \cdot \vec{B}] = I \cdot \vec{l} \times \vec{B}$, where $I \cdot [\vec{l} \cdot \vec{B}] = I \cdot \vec{l} \times \vec{B}$ – is a vector product of quantity $I \cdot \vec{l}$ and a vector \vec{B} that is **the magnetic induction vector** of the magnetic field, I – is a current in the conductor, \vec{l} – is a direction vector of the current flow I of the conductor. By the definition of the vector product, the modulus of the Ampere force is equal to $F_A = I \cdot l \cdot B \cdot \sin \alpha$.

Ampere's law: the force of the magnetic field that acts on a current-carrying conductor is directly proportional to the current, the length of the conductor, and depends on the orientation of the conductor in the magnetic field.

3. Vector of magnetic induction

The magnetic induction vector \vec{B} is the force characteristic of the magnetic field. The modulus of the magnetic induction vector is equal to the ratio of the maximum value of the Ampere force \vec{F}_A ($\sin \alpha = 1$, $\alpha = 90^\circ$) to the product of the current strength and the length of the conductor

$$B = \frac{F_A}{I \cdot l}.$$

All three vectors, \vec{B} , \vec{F}_A and \vec{l} are mutually perpendicular (the angle between the directions of any 2 vectors is 90°), i. e. each vector is perpendicular to the plane in which two other perpendicular vectors are located. In the SI system, the unit of magnetic induction is **Tesla**¹:

$$1 \text{ T} = \frac{1 \text{ N}}{1 \text{ A} \cdot 1 \text{ m}}.$$

¹ Niccolo Tesla (1856–1943) – an American physicist and inventor. He made a great contribution to the development of electrical engineering and the physics of electromagnetism. The unit of magnetic induction is named in his honour.

The magnetic field is plotted graphically using **the magnetic field lines of the vector \vec{B}** . The **force line** of a vector \vec{B} is an imaginary line tangent to which at any point coincides with the direction of the magnetic induction vector at this point. The direction of the force lines of the vector \vec{B} is determined by the rule of the right hand:

- for a conductor of current on a straight trajectory: if the thumb is in the direction of the current, the bent four fingers will indicate the direction of the force line (Fig. 2.3, *a*).

- for a conductor of current on a circular trajectory: if four fingers are in the direction of the current, the thumb at right angles will show the direction of the force line in the centre of the circle (Fig. 2.3, *b*)

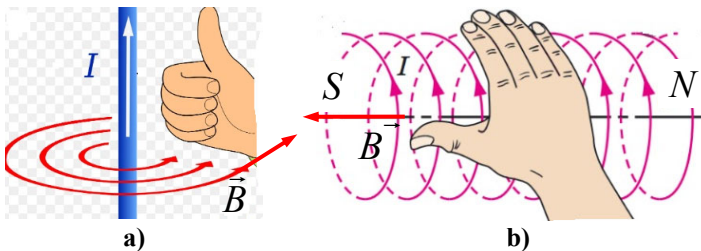

Fig. 2.3

The direction of the magnetic field line is considered to be the direction from the north magnetic pole to the south. Unlike the electric field lines, magnetic field lines are always closed (have neither a beginning nor end) and surround a current-carrying conductor. The direction of the force lines can also be set according to the "drill rule". Fig. 2.4 shows a conductor with current, which is located perpendicular to the page, and a) the direction of current is from the reader (i. e. \times – is the end of the vector); b) the direction of current to the reader (i. e. \cdot – is the beginning of the vector).

The drill when screwed clockwise is screwed into the page and shows the direction of the magnetic field lines (Fig. 2.4, *a*). And vice versa, the force lines for a current from Fig. 2.4, *b* have the opposite direction.

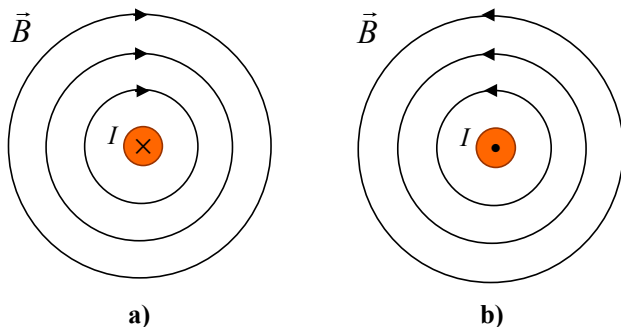

Fig. 2.4

4. Lorentz force

Lorentz explained the existence of Ampere's force by the fact that the magnetic field acts on moving charges in a current-conductive conductor. Thus, the Ampere force is the sum of the forces acting on free charged particles moving in a current-conductive conductor. If the free charge q moves with a velocity \vec{V} in a magnetic field with magnetic induction \vec{B} , the Lorentz force¹ is equal to

$$\vec{F}_L = q[\vec{V} \times \vec{B}],$$

$$F_L = q \cdot V \cdot B \cdot \sin \alpha,$$

where $[\vec{V} \times \vec{B}]$ – is the vector product \vec{V} and \vec{B} , α is the angle between these vectors. Fig. 2.5 describes some examples of the interaction of positive (Fig. 2.5, a) and negative (Fig. 2.5, b) charges with a constant magnetic field. Let the charged particle fly at an angle 90° with a velocity \vec{V} into a constant magnetic field with the force lines directed from the reader perpendicular to the page. In this case, the charged particle will move in a circular trajectory of radius r .

The charged particle that moves perpendicular to the magnetic force lines, will move in a circular trajectory. The Lorentz force does

¹ Hendrik Lorentz (1853–1928) was a Dutch physicist who created the classical electronic theory, with the help of which he explained many electrical and optical phenomena.

not carry out work, but only changes the direction of the velocity of charges and is a centripetal force.

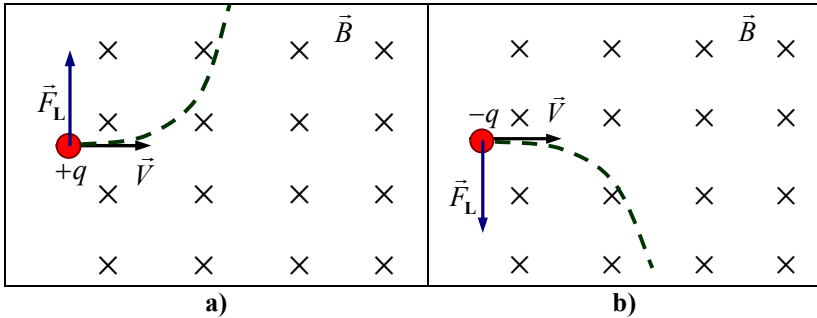

Fig. 2.5

If you increase the magnitude of the magnetic induction, the rotational speed will increase. This concept is used in **particle accelerators** – machines that use electromagnetic fields to propel charged particles to very high speeds and energies to study their properties, the nature of their interaction and the structure of matter.

Problem. The cyclotron (type of particle accelerator) is designed to accelerate protons to an energy of 5 MeV ($1 \text{ MeV} = 10^6 \text{ eV}$, $1 \text{ eV} = 1.6 \cdot 10^{-19} \text{ J}$). Determine the largest radius of the orbit along which the proton can move in accelerator if the magnetic field induction is equal to 1 T (Fig. 2.6).

Given:

$$E_k = 5 \text{ MeV} = 8 \cdot 10^{-13} \text{ J}$$

$$B = 1 \text{ T}$$

$$m_p = 1.67 \cdot 10^{-27} \text{ kg}$$

$$q = 1.6 \cdot 10^{-19} \text{ C}$$

Find: $r - ?$

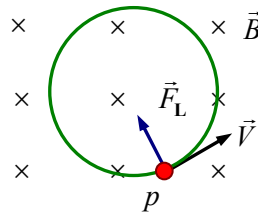

Fig. 2.6

Solution. The proton in a magnetic field is acted upon by the Lorentz force, which is a centripetal force that ensures the movement of the proton in a circle of radius r . The radius will be maximum if the angle between the vector \vec{B} and the velocity \vec{V} is equal to 90° :

$$m_p a = qVB \cdot \sin 90^\circ \Rightarrow m_p \frac{V^2}{r} = qVB.$$

From here $r = \frac{m_p V}{qB}$. The modulus of velocity is found from the expression for the kinetic energy of the proton

$$E_k = \frac{m_p V^2}{2} \Rightarrow V = \sqrt{\frac{2E_k}{m_p}}.$$

Then

$$r = \frac{\sqrt{2m_p E_k}}{qB} = \frac{\sqrt{2 \cdot 1.67 \cdot 10^{-27} \cdot 8 \cdot 10^{-13}}}{1.6 \cdot 10^{-19} \cdot 1} \text{ m} = 0.32 \text{ m},$$

where q – is the proton charge.

Answer: $r = 0.32 \text{ m}$.

Words and phrases

magnetic field	Ampere force	magnet	aurora borealis
magnetic induction	Lorentz force	particle accelerator	north pole
magnetic field lines	cyclotron	current-carrying conductor	south pole

Tasks for independent work

I. Answer the questions

1. What does a magnetic field do?
2. What force is called the Ampere force?
3. How to establish the direction of magnetic force lines in a conductor with the current?
4. What is the Lorentz force?
5. How are the charge velocity vector and the Lorentz force located one relative to the other?

II. Solve the problems

1. Give examples of magnetic phenomena.

2. Describe the nature of aurora borealis.
3. Write the expressions for Ampere force and Lorentz force.
4. An electron describes a circle of radius $r = 4 \cdot 10^{-4}$ m in a homogeneous magnetic field. Its velocity $V = 3.5 \cdot 10^6$ m/s. Find the induction of the magnetic field.
5. A proton and an electron, accelerated by the same potential difference, fly into a homogeneous magnetic field perpendicular to the lines of magnetic induction. How many times the radius of curvature r_1 of the proton trajectory is greater than the radius of curvature of the electron trajectory r_2 ?

Remember!

1. Interaction of two conductors with current is transmitted through a magnetic field.

§ 7. Magnetic flux. Electromagnetic induction

1. Magnetic flux

Magnetic flux is a scalar physical quantity equal to the flux of a magnetic induction vector through a surface $\Phi = B \cdot S \cdot \cos \alpha$, where B – is magnetic induction, S – is a surface area, α – is the angle between the vector \vec{B} and perpendicular to the surface. The physical sense of the magnetic flux is the number of lines of force crossing the surface. The magnetic flux can be both positive and negative. The sign is determined by the choice of the direction in which the perpendicular to the surface is drawn (Fig. 2.7).

The unit of magnetic flux in the SI system is **Weber**¹: $1 \text{ Wb} = 1 \text{ T} \cdot 1 \text{ m}^2$.

¹ Wilhelm Weber (1804–1891) was a German physicist and one of the developers of the theory of electrodynamic phenomena. The unit of measurement of magnetic flux is named in his honour.

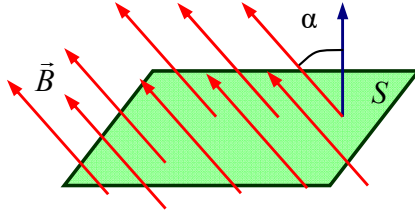

Fig. 2.7

2. Electromagnetic induction

The phenomenon of **electromagnetic induction** was discovered in 1831 by the English physicist Michael Faraday. He observed the appearance of an electric current in **an inductance coil** when the magnetic flux changes. An inductance coil is a conductor with the shape of a circle or can be represented as a set of identical turns of a certain radius. The magnetic flux varied in two ways: when a permanent magnet moved near the coil, or when the conductor moved in a constant magnetic field, i. e. a time-varying magnetic flux caused the appearance of an electromotive force. Therefore, the phenomenon of current in a closed conductive circuit when the magnetic flux changes called **electromagnetic induction**.

Faraday's law of electromagnetic induction: the generated (i. e. induced) electromotive force is directly proportional to the rate of change of magnetic flux:

$$\varepsilon = -\frac{\Delta\Phi}{\Delta t}.$$

A minus sign means that the direction of the induced current has the opposite direction to the phenomenon that caused the *emf*.

Lenz's law: the direction of the electric current induced in a conductor by a changing magnetic field is such that the magnetic field created by the induced current opposes changes in the initial magnetic field.

For an inductance coil that has n identical turns, the value of the *emf* increases proportionally to the number of turns:

$$\varepsilon = -n \cdot \frac{\Delta\Phi}{\Delta t}.$$

3. Self-induction

Let the current I flow from an external source through an inductance coil that has n turns. This current creates a magnetic field in the coil, and therefore through the coils passes its magnetic flux Φ . According to the law of electromagnetic induction, this magnetic flux causes the appearance of *emf*, which is called a **self-induced electromotive force**. And the current it causes is called **the induced current** I_i . The induced current opposes the primary current I that generates the flow Φ .

Self-induction is the phenomenon of production of an induced *emf* in a conductor due to a change in its magnetic flux, which is caused by a change in current in the same conductor.

The magnetic flux in the inductor is directly proportional to the magnitude of the current I flowing through the coil $\Phi = L \cdot I$, where L is the coefficient of proportionality, which is called **inductance**. Inductance characterizes the property of a coil with a current to create a magnetic flux.

The change in magnetic flux is equal to $\Delta\Phi = L \cdot \Delta I$. Let's substitute the expression for $\Delta\Phi$ into the expression of the law of electromagnetic induction. We obtain the equation for determining a self-induced *emf*: $\varepsilon = -L \cdot \frac{\Delta I}{\Delta t}$.

4. The energy of the magnetic field

The phenomenon of electromagnetic induction is evidence of compliance with the law of conservation of energy. Alternating magnetic flux leads to the appearance of electromotive force, which is a source of electrical energy. Thus, it can be argued that the energy of the magnetic field is converted into the energy of electric current, and vice versa, the energy of electric current is converted into energy of magnetic field.

Consider an electrical circuit consisting of a series-connected capacitor C , an inductor L and a switch (Fig. 2.8). Let's charge the

capacitor q . The energy stored in a capacitor is the energy of an electric field that is equal to

$$W_{\text{el}} = \frac{CU^2}{2},$$

where $U = \frac{q}{C}$ – the voltage on the covers of the capacitor. There is no current in the electrical circuit until the circuit breaker (switch) is closed. After closing the circuit, the capacitor begins to discharge and current will flow through the inductor. As a result, the phenomenon of electromagnetic induction appears, which, in turn, causes the appearance of induction current. The induction current has the opposite direction to the initial discharge current of the capacitor. The self-induction current will recharge the capacitor by changing the charge signs on its covers.

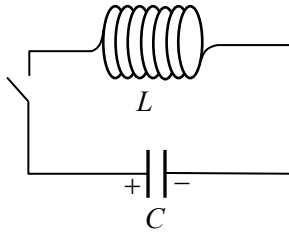

Fig. 2.8

The energy of the magnetic field is concentrated in the inductor and is equal to $W_{\text{m}} = \frac{LI^2}{2}$, where I is the current flowing through the inductor. The total energy of the electromagnetic field is equal to the sum of the energies of the electric and magnetic fields

$$W = W_{\text{el}} + W_{\text{m}} = \frac{CU^2}{2} + \frac{LI^2}{2}.$$

The energy of the electromagnetic field remains unchanged if there is no energy loss in the electric circuit to overcome the resistance of the conductors.

Problem 1. The induction of a uniform magnetic field is equal to 0.5 T. Find the magnetic flux through a frame with an area of 25 cm², placed perpendicular to the lines of induction (Fig. 2.9). Determine the magnetic flux change if the frame is rotated at an angle $\varphi = 60^\circ$ from its original position.

Given:

$$B = 0.5 \text{ T}$$

$$S = 25 \text{ cm}^2 = 2,5 \cdot 10^{-3} \text{ m}^2$$

$$\varphi_1 = 0^\circ$$

$$\varphi_2 = 60^\circ$$

Find: $\Phi_1 = ?$ $\Phi_2 = ?$

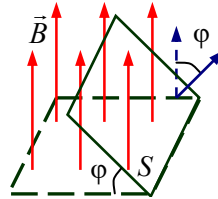

Fig. 2.9

Solution

$$\Phi_1 = B \cdot S \cdot \cos \varphi_1; \quad \Phi_2 = B \cdot S \cdot \cos \varphi_2;$$

$$\Phi_1 = 0.5 \cdot 2.5 \cdot 10^{-3} \cdot \cos 0^\circ = 1.25 \cdot 10^{-3} \text{ Wb};$$

$$\Phi_2 = 0.5 \cdot 2.5 \cdot 10^{-3} \cdot \cos 60^\circ = 1.25 \cdot 10^{-3} \cdot 0.5 \text{ Wb} = 6.25 \cdot 10^{-4} \text{ Wb}.$$

Answer: $\Phi_1 = 1.25 \cdot 10^{-3} \text{ Wb}$; $\Phi_2 = 6.25 \cdot 10^{-4} \text{ Wb}$.

Problem 2. The magnetic flux that permeates the circuit decreases from 9 mVb to 4 mVb during the time of 5 ms. Determine a self-induced *emf* in the circuit.

Solution. The self-induced *emf* is equal to

$$\varepsilon = -\frac{\Delta\Phi}{\Delta t} = -\frac{\Phi_2 - \Phi_1}{\Delta t} = -\frac{(4 - 9) \cdot 10^{-3} \text{ Wb}}{5 \cdot 10^{-3} \text{ s}} = 1 \text{ V}.$$

Answer: $\varepsilon = 1 \text{ V}$.

Words and phrases

a self-induced <i>emf</i>	electromagnetic field	Weber	turn
electromagnetic induction	magnetic flux	induction current	coil

Tasks for independent work

I. Answer the questions

1. What is called a magnetic flux?
2. In what units is the magnetic flux measured?
3. Formulate the law of electromagnetic induction.
4. In what units is electromagnetic induction measured?
5. Why does the phenomenon of self-induction occur?
6. Formulate Lenz's law.

II. Solve the problems

1. Write the expressions of Faraday's law.
2. Write an expression for the energy of the magnetic field.
3. Find the rate of change of magnetic flux in the coil that consists of 2000 turns when the a self-induced emf 120 V is excited in it.
4. In a coil of 200 turns, a constant self-induced emf 160 V is excited. Determine the magnetic flux changes through each of the turns during 5 ms?
5. A wire coil of radius 1 cm, with a resistance of $1\text{ m}\Omega$, is penetrated by a homogeneous magnetic field with the lines of induction that are perpendicular to the plane of the coil. The induction of the magnetic field changes smoothly at a rate of 0.01 T/s. How much heat will be released in the coil in 1 minute?

Remember!

1. The current creates a magnetic field.
2. The magnetic field of the induced current counteracts the change in magnetic flux.

§ 8. Alternating current. Electromagnetic waves

1. Oscillations in electrical circuits

If an electric circuit consists of a series-connected capacitor and an inductor (Fig. 2.8), the fluctuations in electric current and voltage will appear in it. The electric circuit described above is called

an oscillating circuit. The oscillations in the oscillating circuit are harmonic in the absence of resistance of the conductors.

Harmonic oscillations are the oscillations of system parameters that change according to the law of **sine** or **cosine**. According to the laws of sine or cosine in an electric circuit, the changes of charge, voltage and current are described. In the case of the absence of electrical resistance in an electric circuit, the oscillations will not be damped.

To occur **free oscillations** in the oscillating circuit, the system should transfer energy, for example, to charge a capacitor. At the initial moment on the covers of the capacitor will be the maximum electric charge q_{\max} . The magnitude of the charge changes over time according to the law $q(t) = q_{\max} \cdot \cos \omega t$, where ωt – the phase of oscillations, ω – the cyclic frequency of oscillations.

In 1853, the English physicist William Thomson (Lord Kelvin) obtained an equation for the period of own oscillations of an electric oscillatory circuit $T = 2\pi \cdot \sqrt{LC}$. According to this equation, the cyclic frequency of natural oscillations is equal to

$$\omega = \frac{2\pi}{T} = \frac{1}{\sqrt{LC}}.$$

To determine the current in a circuit, it is necessary to find the derivative of the charge change function over time:

$$I(t) = \frac{dq}{dt} = q'(t) = -q_{\max} \omega \cdot \sin \omega t,$$

$$I(t) = -q_{\max} \omega \cdot \sin \omega t,$$

where $I_{\max} = q_{\max} \omega$ is the maximum current in the circuit.

The change in voltage on the covers of the capacitor coincides with the change in charge

$$U(t) = \frac{q_{\max}}{C} \cdot \cos \omega t = U_{\max} \cdot \cos \omega t.$$

2. Vortex electric field

The occurrence of induction current in the oscillating circuit leads to a change in magnetic flux. In this case, an electric current appears and creates an alternating magnetic field. This alternating magnetic field is the cause of induction electric current. The electric field itself can be created not only by electric charges. The electric field that occurs when the magnetic field changes is called a **vortex electric field**. The work of the forces of the vortex electric field to move electric charges lead to creating an induction *emf*. The vortex electric field is not connected with electric charges, its lines of tension are closed.

In 1865, the Scottish physicist James Maxwell developed the theory of the electromagnetic field. He hypothesized that the electric and magnetic fields have the same properties. At any change of an electric field a vortex magnetic field **is created in surrounding space**. Conversely, with any change of the magnetic field in the surrounding space, there is a vortex electric field. As a result, a system of coupled alternating electric and magnetic fields is formed (Fig. 2.10).

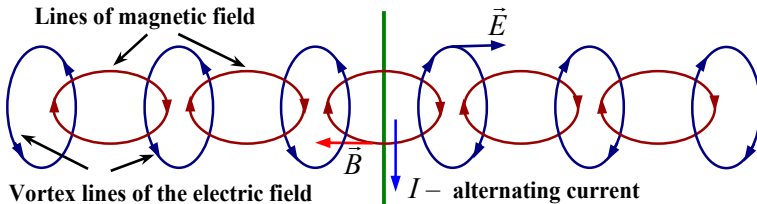

Fig. 2.10

3. Electromagnetic waves

The theory of the electromagnetic field is based on Maxwell's equations in integral and differential form. These equations describe the electromagnetic field as the oscillations of mutually perpendicular vectors of the electric field and magnetic induction that propagate in space over time. The electromagnetic field

propagates in the form of a transverse electromagnetic wave, which consists of two waves – electric and magnetic with the same phases of oscillations (Fig. 2.11).

An electromagnetic wave is defined as a propagating couple of electric and magnetic field components in space.

The speed of propagation of an electromagnetic wave is the distance that the electromagnetic wave can pass per unit of time. The speed of propagation of electromagnetic waves in a vacuum is constant and equal to the speed of light in vacuum: $c = 3 \cdot 10^8$ m/s .

The wavelength λ is the spatial period of a periodic wave—the distance over which the wave's shape repeats (a distance to which the electromagnetic wave propagates in a time equal to the period of its oscillations). The wavelength is related to the speed of its propagation in vacuum by the equation

$$c = \frac{\lambda}{T} = \lambda \cdot \nu ,$$

where T – the period of oscillations, ν – the frequency of oscillations (Fig. 2.11).

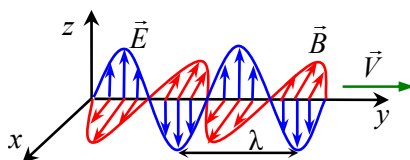

Fig. 2.11

The speed of an electromagnetic wave in a vacuum is the maximum possible speed in nature. During the transition from one medium to another, both the speed of propagation and the wavelength of an electromagnetic wave change. However, the oscillation frequency of the electromagnetic wave remains constant.

In 1888, Heinrich Hertz created an electromagnetic wave using an electromagnetic oscillation **generator**. The scheme of his generator is shown in Fig. 2.12. He also studied the properties of electromagnetic waves, which are predicted by Maxwell's equations.

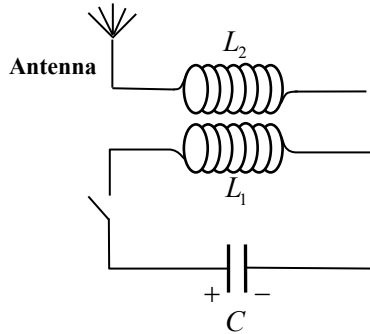

Fig. 2.12

Hertz's experiments showed that electromagnetic waves are reflected from a conductor, refracted at the boundary of another medium, and overcome some obstacles. In this case, **the reflection, refraction, interference, diffraction and polarization** of electromagnetic waves occur according to the same laws that apply to light (the properties of light will be discussed in other paragraphs). Thus, Heinrich Hertz confirmed Maxwell's conclusion about the electromagnetic nature of light. The name of electromagnetic waves depending on their length is given in Table 2.1.

Table 2.1

Name	Wavelength
Long-wave radio waves	1 000 000 km – 15 km
Standard radio waves	15 km – 10 cm
Short radio waves	10 cm – 0.1 mm
Infrared (IR)	100 μm – 0.8 μm
Visible light	800 nm – 400 nm
Ultraviolet (UV)	400 nm – 5 nm
X-rays	5 nm – 0.004 nm
Gamma rays	0.004 nm – 0.0001 nm

Problem. How many times will the period of oscillations increase in the oscillating circuit if we connect to a flat air condenser the same condenser in parallel, but the space between the plates of a second condenser is filled with a dielectric medium mica of dielectric constant 6 (Fig. 2.13).

Given:

$$\epsilon_1 = 1$$

$$\epsilon_2 = 6$$

$$\text{Find: } \frac{T_2}{T_1} - ?$$

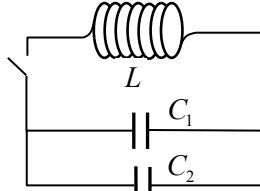

Fig. 2.13

Solution. The period of oscillations in the oscillatory circuit is determined by Thomson's equation $T = 2\pi\sqrt{LC}$. The capacitance of a flat capacitor is equal to

$$C = \frac{\epsilon_0 \epsilon S}{d}.$$

Then

$$C_1 = \frac{\epsilon_0 \epsilon_1 S}{d}, \quad C_2 = \frac{\epsilon_0 \epsilon_2 S}{d}.$$

With a parallel connection, the total capacitance will be equal to

$$C_{\text{total}} = C_1 + C_2 = \frac{\epsilon_0 S}{d} + \frac{6 \cdot \epsilon_0 S}{d} = 7 \frac{\epsilon_0 S}{d} = 7C_1.$$

Then the ratio of periods will be equal

$$\frac{T_2}{T_1} = \frac{2\pi\sqrt{L(C_1 + C_2)}}{2\pi\sqrt{LC_1}} = \sqrt{\frac{7C_1}{C_1}} = \sqrt{7} \approx 2.65,$$
$$T_2 \approx 2.65 \cdot T_1.$$

Answer: The period of oscillation will increase approximately by 2.65 times.

Words and phrases

oscillating circuit	reflection	alternating current	interference
electromagnetic wave	refraction	harmonic oscillation	diffraction
vortex field	polarization	generator	surrounding space

Tasks for independent work

I. Answer the questions

1. What is an oscillating electrical circuit?
2. What oscillations of electric current are called harmonic oscillations?
3. What is a vortex electric field? What is the difference between a normal electric field and a vortex electric field?
4. What is called an electromagnetic wave? What are the main characteristics of electromagnetic waves?
5. What are the main properties of an electromagnetic wave?

II. Solve the problems

1. Write the law of the charge changes in the condenser in an oscillatory circuit with the presence of harmonic oscillations.
2. Find the derivative of changing the charge and get the function of changing the electric current in the oscillating circuit.
3. List the names of electromagnetic waves by their length.
4. The amplitude of the current in the circuit is 1 mA, the maximum charge of the capacitor is $10 \mu\text{C}$. Determine the cyclic frequency of oscillations.
5. The charge of the capacitor in the oscillating circuit changes according to the law $q = 5 \cdot 10^{-6} \sin 10^3 \pi t$. Determine the maximum magnetic flux that permeates the coil if the capacitance of the capacitor is $2 \mu\text{F}$.

Remember!

1. James Maxwell created a theory of the electromagnetic field.
2. Heinrich Hertz confirmed Maxwell's conclusion about the electromagnetic nature of light.

CHAPTER 3

Optics

§ 9. Geometric optics

1. The nature of light

Optics is a branch of physics that studies the nature of light, the laws of propagation of light waves and the processes of interaction of light with matter. Optics is conventionally divided into three parts: geometric, wave and quantum optics. **Geometric optics** consider light as a rectilinear ray. **Wave optics** consider light as an electromagnetic wave. **Quantum optics** consider light as a stream of photons. According to modern ideas, light is a complex electromagnetic process that has both **wave** and **corpusculum** (from the Latin *corpusculum* – particle) properties.

Interference, diffraction, and the polarization of light – are the physical phenomena explained by the wave properties of light, named as the **wave theory of light**.

Photoelectric effect, atomic and molecular spectra, thermal radiation are some examples of physical phenomena that are due to the corpuscular properties of light and described by **quantum theory**. Wave (electromagnetic) and corpuscular (quantum) theories complement each other and reflect the dualistic properties of light. **Dualistic properties (dualism)** means that light is both a wave and a particle.

2. Laws of reflection and refraction of light

In a homogeneous medium, the propagation of light is **rectilinear**. The geometric line that indicates the direction of light propagation is called **the light beam**. The formation of the shadow is due to **the straightness** of light propagation.

A large number of observations and experiments have established **four basic laws** of optical phenomena:

- 1) the law of rectilinear propagation of light;
- 2) the law of independence of light rays;
- 3) the law of reflection of light;
- 4) the law of refraction.

The reflection of light is a change in the direction of the beam at the boundary of two media when the beam remains in the same medium (Fig. 3.1). Here AO is an incident ray; OB is the reflected beam, OC is the perpendicular drawn at the point of incidence of the light to the boundary between two media.

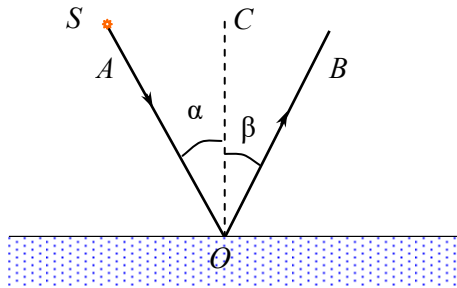

Fig. 3.1

Laws of light reflection:

- 1) the incident ray AO and reflected ray OB lie in the same plane with the perpendicular OC to the boundaries between two media;
- 2) the angle of reflection β is equal to the angle of incidence α .

The reflection of light that satisfies these laws is called **a mirror reflection**. If the condition of a mirror reflection is not fulfilled, the reflection is called **diffuse**.

Refraction of light is the effect, when the optical ray changes its direction after it passes the boundary between two environments (Fig. 3.1), where S is the light source, AO is the incident ray, and OB is the refracted ray. The ratio of the speed of light in vacuum c to the speed of light V in the medium is called **the absolute refractive**

index of this medium: $n = \frac{c}{V}$.

The **relative refractive index** n_{21} of the second medium relative to the first one is the ratio of the speed of light in the first medium V_1 to the speed of light in the second medium V_2 :

$$n_{21} = \frac{V_1}{V_2} = \frac{n_2}{n_1},$$

where n_1 and n_2 – are the absolute refractive indices of the first and second media, respectively (Fig. 3.2). If $n_{21} > 1$, then the second medium is called the **optically denser medium** (with higher optical density) than the first medium. Table 3.1 shows the speed of light in some typical environments.

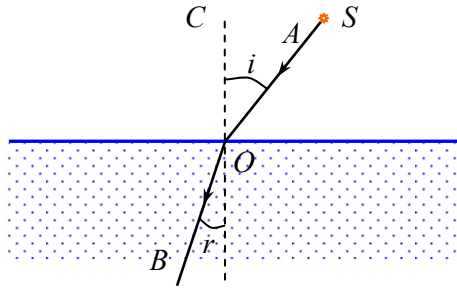

Fig. 3.2

Table 3.1

Media	The velocity of light, m/s
air	$3 \cdot 10^8$
water	$2.25 \cdot 10^8$
glass	$1.98 \cdot 10^8$
diamante	$1.24 \cdot 10^8$

Laws of refraction:

1) the refracted beam OB and the incident beam AO lie in the same plane with the perpendicular OC to the boundary of the media at the point of beam incidence;

2) the ratio of the sine of the angle of incidence to the sine of the angle of refraction with the perpendicular CO is a constant value for the two media and is equal to the refractive index of these media

$$\frac{\sin i}{\sin r} = \frac{n_2}{n_1} = n_{21}.$$

The laws of reflection and refraction of light are valid for homogeneous media with the absence of light absorption.

The refraction phenomenon can be also observed as a result of the refraction of light rays in different layers of the same substance, which have different refractive indices. For example, the layers of air near the Earth's surface have a higher temperature and, accordingly, a different refractive index. Therefore, it is possible to distort the image of objects. Thus, refraction is also a phenomenon of curvature and distortion of light rays in layers of one substance with different refractive indexes.

3. The phenomenon of total internal reflection

If light rays fall from a medium with a higher optical density (glass) into a medium with a lower optical density (water), at angles of incidence $i \geq i_{\text{cr}}$ (where $\sin i_{\text{cr}} = n_{21}$) the refraction of light does not occur. In case of $i = i_{\text{cr}}$ the angle of refraction is equal to

$r = \frac{\pi}{2}$. So, for angle $i < i_{\text{cr}}$ we can observe the refraction of light,

but for the angle $i > i_{\text{cr}}$ – the light does not cross the boundary with another medium (Fig. 3.3). This phenomenon is called **total internal reflection**. If the light passes from the medium $n_1 = n$ into the air (for which $n_2 \approx 1$), the condition of complete internal

reflection will take the form $\sin i_{\text{cr}} = \frac{1}{n}$.

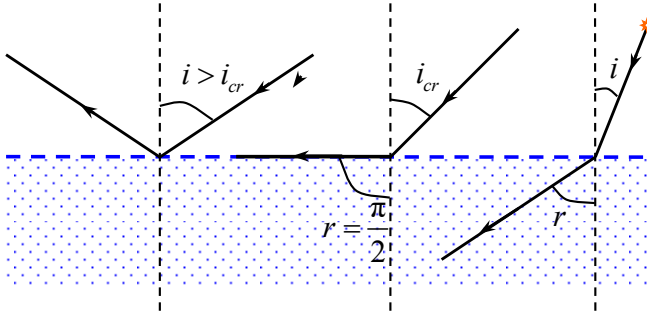

Fig. 3.3

4. Dispersion of light

When the white light moves through a glass **prism** it decomposes into components and forms a coloured band of seven colours (which is called **the dispersion spectrum**) on the screen after the prism. Light of different colours has different wavelengths (Fig. 3.4). The phenomenon of the dependence of the refractive index of matter on the wavelength of light is called **the dispersion of light** $n = f(\lambda)$ (Fig. 3.5).

The decomposition of natural light and the formation of the spectrum is a consequence of dispersion. If the refractive index decreases with increasing wavelength, the dispersion of light is called **normal dispersion**, otherwise – **anomalous dispersion**.

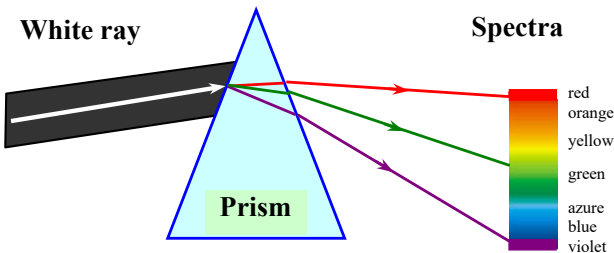

Fig. 3.4

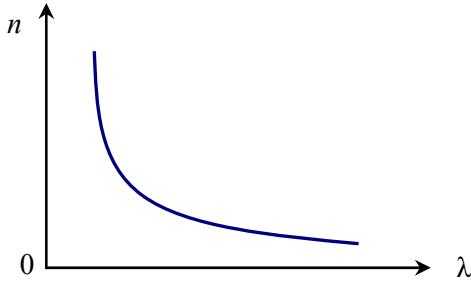

Fig. 3.5

5. The lens formula

An **optical lens** is an optically transmissive element that focuses or disperses a light beam using refraction. Lenses are made of transparent material: glass, plastic, quartz, etc. The human eye has a natural lens – a lens of the eye. The lenses have two or one spherical surface. A thin lens is a lens whose thickness is much less than the curvature of its surface. Lenses are divided into convex and concave. Convex lenses collect the incoming rays (**condenser lens**, Fig. 3.6, *a*), and concave lenses scatter the incoming rays (**scattering lens**, Fig. 3.6, *b*).

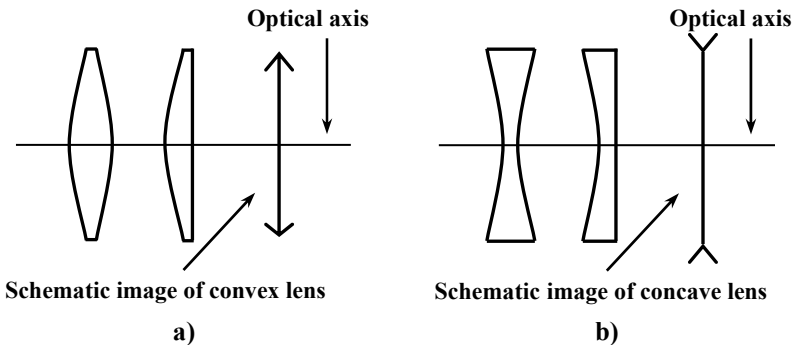

Fig. 3.6

A **focal plane** is a plane that is perpendicular to the axis of a lens or mirror and passes through the focus. **Focus** is the point of

intersection of the optical axis with the focal plane. A ray parallel to the optical axis intersects the optical axis in focus after refraction. The beam that passes through the centre of the lens O does not change its direction, i. e. passes through the lens without refraction. Since light can pass through a lens in either direction, a lens has two focuses and focal planes – one on each side (Fig. 3.7).

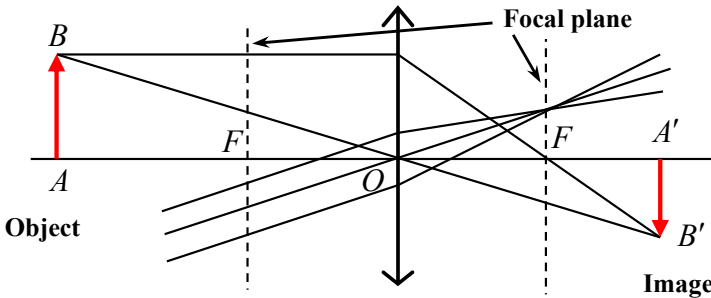

Fig. 3.7

The optical properties of the lens are determined by **the focal length F or optical power $D = \frac{1}{F}$** . The unit of measurement of optical power is **the dioptre** – $1D = \frac{1}{\text{m}}$. One dioptre is the optical power of a system with a focal length of 1 m.

The focal length of the lens F is related to the distance from the lens to the object and its image by a ratio called **the lens formula**

$$\frac{1}{F} = \frac{1}{d} + \frac{1}{f},$$

where F – is the focal length (distance $|OF|$ from the focus F to the centre of the lens), d is the distance $|AO|$ from *the object* to the centre of the lens, f is the distance $|OA'|$ from **the image** of the object to the centre of the lens (Fig. 3.7).

The rules of signs when applying the formula of the lens:

1) $\frac{1}{F}$ is preceded by a sign "+", if the lens is collapsible, or by a sign "-" if the lens is scattering;

2) $\frac{1}{f}$ is preceded by a sign "+" if the image is real, or by a sign "-" if it is imaginary;

3) $\frac{1}{d}$ preceded by a sign "+" if the object is real (a divergent beam of rays falls on the lens), or by a sign "-" if the object is imaginary (a convergent beam of rays falls on the lens).

Problem 1. The wavelength of light of the red line in the hydrogen spectrum is 656 nm. Determine the wavelength of the same light in the glass if the refractive index of the glass for these rays $n = 1.51$.

Given:

$$\lambda_0 = 656 \text{ nm}$$

$$n = 1.51$$

Find: λ - ?

Solution. When light passes from one medium to another, the frequency of light does not change, but the wavelength changes. For vacuum $\lambda_0 = \frac{c}{\nu}$, for glass $\lambda = \frac{V}{\nu}$, then $\frac{\lambda_0}{\lambda} = \frac{c}{V}$. Since $\frac{c}{V} = n$, then

$$\frac{\lambda_0}{\lambda} = n. \text{ From here } \lambda = \frac{\lambda_0}{n} = \frac{656 \text{ nm}}{1.51} = 434 \text{ nm}.$$

Answer: $\lambda = 434 \text{ nm}$.

Problem 2. A ray of light falls on a glass plate that has a refractive index $n = 1.5$. Find the angle of incidence of the beam if the angle between the refracted and reflected rays is 90° .

Given:

$$n = 1.5$$

$$\gamma = 90^\circ$$

Find: i = ?

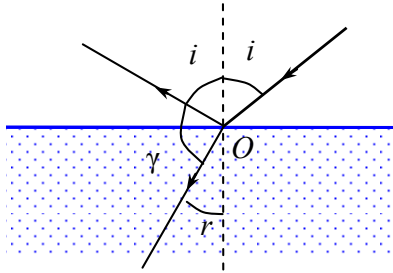

Fig. 3.8

Solution. From Fig. 3.8 shows that $i + \gamma + r = 180^\circ$. Hence $r = 180^\circ - i - \gamma$, $r = 90^\circ - i$. According to the law of $\frac{\sin i}{\sin r} = n$, where $\sin r = \sin(90^\circ - i) = \cos i$, then $\frac{\sin i}{\cos i} = n$, $i = \arctg n \approx 0.98 \text{ rad}$.

Answer: $i \approx 0.98 \text{ rad} \approx 56^\circ$.

Words and phrases

optics	absolute refractive index	relative refractive index	reflection and refraction of light
diffuse reflection	dualism	homogeneous medium	dispersion
corpuscle	prism	total internal reflection	specular reflection
light source	shadow	light ray	spectrum

Tasks for independent work

I. Answer the questions

1. What does optics study?
2. What phenomena are due to the wave properties of light?
3. What phenomena are due to the corpuscular properties of light?
4. What does the dualism of light mean?
5. What is called the reflection, refraction and dispersion of light?

II. Solve the problems

1. Write expressions for absolute and relative refractive indices.
2. Write down the condition of total internal reflection.
3. The speed of light in water $2.25 \cdot 10^8$ m/s and in glass $2.0 \cdot 10^8$ m/s . Find the refractive index of glass relative to water.
4. The beam falls from the glass into the water. Find the ratio of the speeds of light in these environments. Find the angle of refraction if the angle of incidence is 30° .
5. The object is placed at a distance of 0.15 m from the scattering lens with a doubled focal length ($2F$) of 0.6 m. At what distance from the lens is the image of the object?

Remember!

Light of different colours is characterized by different refractive indices in this environment.

§ 10. Wave optics

1. Interference of light

Consider the phenomena in which light exhibits wave properties. **Interference of light** in which two or more coherent light waves superpose to form the resultant wave of the lower, higher or same amplitude. **Coherent waves** are the waves that have the same frequencies and must maintain a constant phase difference with respect to each other.

Consider the superposition of two coherent waves in Young's experiment. Let the light from the source S waves arrive at the barrier that contains two parallel slits S_1 and S_2 . The light waves from both slits become to be the coherent waves and produce on a viewing screen a visible pattern of bright and dark parallel bands called **fringes** (Fig. 3.9). Consider a point A on the screen, which is located at distances r_1 and r_2 from S_1 and from S_2 , respectively.

The difference $r_2 - r_1$ is called **the path difference** in the course of the waves $\Delta = r_2 - r_1$. **The phase difference** $\Delta\varphi$ depends on the geometric difference in the course of the rays

$$\Delta\varphi = \frac{2\pi\Delta}{\lambda}.$$

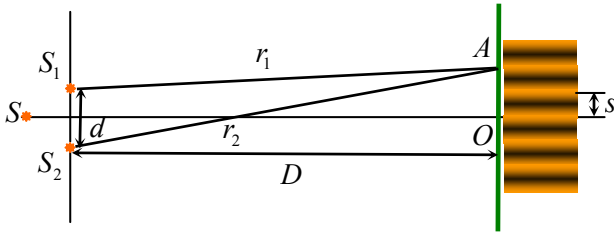

Fig. 3.9

The constructive interference (the condition for bright fringes) is observed at those points on the screen for which the path difference Δ is equal to an integer number of waves $\Delta = k\lambda$ or even to a number of half-waves $\Delta = 2k \cdot \frac{\lambda}{2}$, where λ is the wavelength, $k = 0, \pm 1, \pm 2 \dots$ – is the **order number**. At these points, the waves come with the same phases.

The destructive interference (the condition for dark fringes) is observed in those points for which the difference of the course Δ is equal to an odd number of half-waves:

$$\Delta = (2k + 1) \cdot \frac{\lambda}{2},$$

At these points the waves come with opposite phases. The distance between two adjacent maxima s is equal to

$$s = \frac{\lambda D}{d},$$

where d – is the distance between the slits, D – is the distance from the slits to the screen (it should be assumed that $D \gg d$). Measuring the value s for known distances d and D allows you to experimentally determine the wavelength of light λ .

2. Diffraction of light

Diffraction of light is a phenomenon of bending of waves as they pass by some objects or through an aperture. The phenomenon of diffraction can be understood using **Huygens's principle** which states that every unobstructed point on a wavefront will act as a source of secondary spherical waves. The new wavefront is the surface tangent to all the secondary spherical waves.

Diffraction is, for example, the envelope of obstacles by light waves, i. e. the penetration of a wave into the region of a geometric shadow. The very phenomenon of diffraction is often interpreted as a case of interference of waves limited in space (as the **interference of secondary waves** formed after the light bends while encountering any obstacle). Consider the slit BC with width b , which is an obstacle in the path of the rays to the screen (Fig. 3.10).

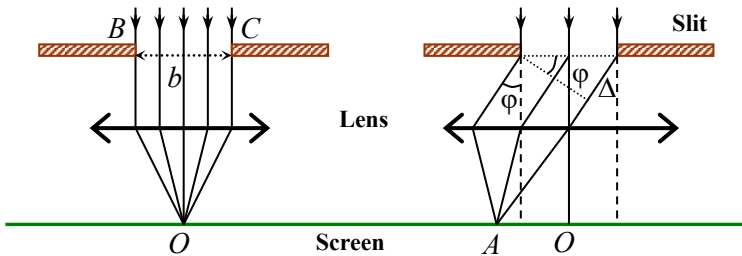

Fig. 3.10

The lens collects all parallel rays at one point in the focal plane of the lens (point O in Fig. 3.10). Since the lens does not give a path difference, at point O there will be a central light band (main maximum). Secondary rays from the slit can propagate at an arbitrary angle ϕ , called the **diffraction angle**. The screen will show a diffraction pattern: alternation of dark and light bands symmetrical about the central light band at point O . At any point A (Fig. 3.10) a maximum, minimum, or intermediate value of intensity can be observed (depending on the ratio between the width of the slit, angle ϕ and wavelength λ).

3. Diffraction grating

A diffraction grating is an optical component with a regular structure. The simplest diffraction grating is a system of N identical slits in width b and separated from the next by the same opaque intervals with a width a (Fig. 3.11). The light wave is divided by the lattice slits into separate coherent secondary waves. These waves are diffracted in the slits and interfere. Since the constructive interference is detected at different angles for different wavelengths (due to the difference in the course of the interfering rays), a white light decomposes into a spectrum. The value $d = b + a$ is called the lattice constant, or **lattice period**.



Fig. 3.11

The condition for the principal diffraction maxima on the diffraction grating is observed at angles φ that satisfy the condition

$$d \sin \varphi = n\lambda \quad (n = 0, 1, 2 \dots).$$

And vice versa, the diffraction minima are determined by the condition

$$b \sin \varphi = m\lambda \quad (m = 1, 2, 3 \dots).$$

The diffraction grating is the simplest optical device for measuring wavelengths of light.

4. Polarization of light

Light waves are the propagation of transverse electromagnetic oscillations. The direction of oscillation of the light wave is perpendicular to the direction of wave propagation. A real light source consists of many atoms that emit chaotically. Thus, the light waves have different planes of oscillation. It means that each ray of a real light source has numerous oriented oscillation planes. Such a ray is natural light, or unpolarized light (Fig. 3.12, *a*).

Natural light can be **polarized**, i. e. we can create conditions for the oscillations of the electric field vector to occur in an orderly

manner, for example, along one direction OO' (Fig. 3.12, *b*). Light in which the electrical oscillations occur in only one plane is called **plane-polarized light**. The light emitted by a single atom is polarized throughout the whole emitting period. Light reflected from the interface of dielectrics will be completely polarized in the plane perpendicular to the plane of incidence if the angle of incidence i satisfies the condition $\operatorname{tg} i = n_{21}$ (**Brewster's law**), where n_{21} is the relative refractive index. Natural light can be polarized when passing in some directions through certain substances, such as tourmaline.

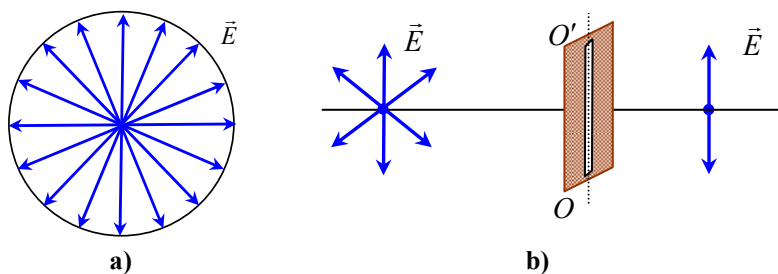

Fig. 3.12

Problem. Find the largest order of the spectrum for the yellow line of Na with a wavelength of 589 nm, if the period of the diffraction grating is 2 μm .

Solution. From the diffraction grating formula $d \sin \varphi = n\lambda$. The order of the spectrum will be maximum when $\sin \varphi = 1$, i. e. at the angle of deviation $\varphi = 1.57 \text{ rad}$. Therefore $n = \frac{\lambda}{d}$, $n = 3$.

Answer: $n = 3$.

Words and phrases

coherent sources	diffraction grating	spectrum	monochromatic light
band	path difference	luminosity	diffraction
interference	natural light	light attenuation	polarized light
light amplification	obstacle	phase difference	screen

Tasks for independent work

I. Answer the questions

1. What is called light interference?
2. What is called a coherent light source?
3. What means the path difference of the waves?
4. What phenomenon is called diffraction of light?
5. What is a diffraction grating?
6. What is called the polarization of light?

II. Solve the problems

1. Formulate the conditions of constructive and destructive interference.
2. Write down the condition of diffraction maxima and minima.
3. The path difference of two interfering waves in a vacuum is equal to: a) 0; b) 0.2λ ; c) 0.5λ . Find the corresponding phase differences?
4. A monochromatic light falls at a right angle (90°) to the diffraction grating with period $d = 0.004$ mm. In this case, the main maximum of the fourth-order corresponds to the deviation of the rays by an angle of 30° . Determine the wavelength of light.

§ 11. Basic concepts of quantum optics

1. Photons

According to quantum theory, light is emitted by individual portions of energy – **quanta**. The elementary part of a light, which is a quantum of the electromagnetic field, is called a **photon**. In quantum optics, light is considered a **stream of photons**.

The main characteristics of a photon are its energy E and momentum p . The energy of a photon is proportional to its frequency or inversely proportional to the wavelength

$$E = h\nu, \text{ or } E = h \frac{c}{\lambda},$$

where c – is the speed of light in vacuum; ν – is a frequency, λ – is the wavelength of light in vacuum, $h = 6.63 \cdot 10^{-34}$ J·s – is a

Planck¹ constant. If the photon energy $E = h\nu$ is equated to **relativistic energy**² $E = mc^2$, then we can find **the relativistic mass** of the photon

$$m = \frac{h\nu}{c^2} = \frac{h}{c\lambda}.$$

The relativistic mass of a photon is an analogue of the classical mass of a body, which is included in the expressions of kinetic energy and momentum of a moving body with velocity $V \ll c$. Relativistic mass m_r and classical mass m_{cl} are related by a relation

$$m_r = \frac{m_{cl}}{\sqrt{1 - \frac{V^2}{c^2}}}.$$

The mass of a photon is not related to **the rest mass** (classical body mass). The rest mass of the photon is zero. A photon at a state of rest does not exist. If we consider a photon as a particle, then its momentum is equal to

$$p = mc = \frac{h\nu}{c} = \frac{h}{\lambda}.$$

The energy and momentum of a photon are expressed in terms of wave characteristics: frequency or wavelength in a vacuum. At low frequencies ν , the wave properties of light predominate, and at high frequencies ν , quantum properties predominate. Thus, the expressions for the energy and momentum of a photon combine the corpuscular and wave properties of light (**wave-particle duality**).

2. Photoelectric effect (photoeffect)

Photoelectric effect (photoeffect) is the emission of electrons when electromagnetic radiation, such as light, hits a material.

¹Max Planck (1858–1947) – a German physicist and one of the founders of quantum mechanics. In 1900 he denied the continuity of energy radiation and put forward the idea of the existence of a quantum – an indivisible portion of energy $h\nu$.

²The relativistic theory, or the relativity theory, developed by A. Einstein in 1905, describes changes in mass, length, energy, momentum, and time for bodies that move at speeds close to the speed of light.

Electrons emitted in this manner are called **photoelectrons**. For solids and liquids, external and internal photoelectric effects are considered. The emission of electrons inside the material when photons hit the metal surface is called the **internal photoelectric effect**. The emission of electrons from the metal surface into a vacuum is distinguished as the **external photoelectric effect**. The external photoelectric effect is observed in experiments on knocking out electrons from the surface of metals under the action of light rays. There are three experimentally established **laws of the photoelectric effect**:

- 1) the maximum initial velocity V_{\max} of photoelectrons depends on the frequency of light and the properties of the metal surface;
- 2) the total number of photoelectrons n that emit from the cathode per unit time, and the strength of the saturation photocurrent I_s are directly proportional to the intensity of the incident light;
- 3) for each substance there exists a certain minimum frequency of incident radiation (**the threshold frequency, ν_{\min}**) below which no photoelectrons are emitted.

A schematic of the experiment to demonstrate the photoelectric effect is shown on Fig. 3.13. The light beam hits the cathode C – a metal plate. Electrons are extracted from the illuminated plate, and under the action of the potential difference go to the anode A . The electric circuit becomes closed and the ammeter shows a current I . When the light is turned off, the current disappears.

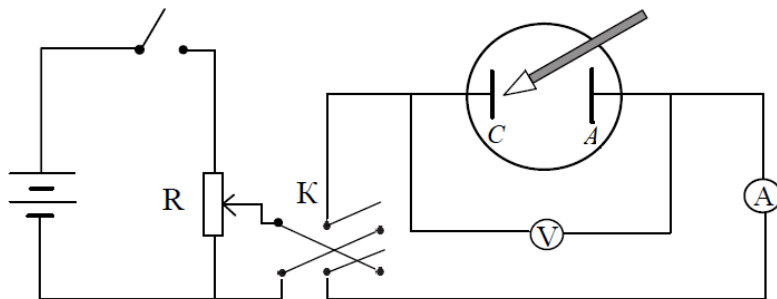

Fig. 3.13

German physicist Albert Einstein took into account the quantum nature of the photon and explained the laws of the external photoelectric effect. **Einstein's equation for the photoeffect:**

$$h\nu = \frac{mV^2}{2} + A_f.$$

The energy of the photon $h\nu$ is spent on the work of the electron coming out of the metal A_f and providing the electron with kinetic energy $mV^2/2$. The external photoelectric effect is possible when $h\nu_{\min} \geq A_f$.

The threshold frequency of photoelectric effect depends only on the work function of the electron, i.e. on the chemical nature of the metal

$$\nu_{\min} = \frac{A_f}{h} \quad \text{or} \quad \lambda_{\max} = \frac{ch}{A_f}.$$

When $\lambda > \lambda_{\max}$ – the photoeffect is not observed. The phenomenon of the photoeffect is used in engineering, and the devices that are based on the photoelectric effect are called **photocells**.

Problem. Find the maximum velocity of an electron emitted from tungsten when illuminated by light with a wavelength of 180 nm, if the work function of the electron is $7.2 \cdot 10^{-19}$ J.

Given:

$$\lambda = 1.80 \cdot 10^{-7} \text{ m}$$

$$A_f = 7.2 \cdot 10^{-19} \text{ J}$$

Find: $V_{\max} = ?$

Solution. The Einstein's equation for the photoelectric effect

$$h\nu = \frac{mV^2}{2} + A_f,$$

where $m = 9.1 \cdot 10^{-31}$ kg – is the mass of the electron; $\nu = \frac{c}{\lambda}$ – is a frequency of light. Then

$$V_{\max} = \sqrt{\frac{2}{m} \left(\frac{hc}{\lambda} - A_f \right)}.$$

$$V_{\max} = \sqrt{\frac{2}{9.1 \cdot 10^{-31} \text{ kg}} \left(\frac{6.63 \cdot 10^{-34} \text{ J} \cdot \text{s} \cdot 3 \cdot 10^8 \text{ m/s}}{1.80 \cdot 10^{-7} \text{ m}} - 7.2 \cdot 10^{-19} \text{ J} \right)} \approx$$

$$\approx 9.2 \cdot 10^5 \text{ m/s}.$$

Answer: $V_{\max} \approx 9.2 \cdot 10^5 \text{ m/s}.$

Words and phrases

quantum of light	cathode	Einstein's equation	photoelectron
photon	anode	photoelectric effect	Planck's constant
rest mass	relativistic mass	work function	threshold frequency

Tasks for independent work

I. Answer the questions

1. What is the name of an elementary particle of light?
2. What is the energy in a photon?
3. Why is the rest mass of a photon equal to zero?
4. What is called a photoelectric effect?
5. What is the physical meaning of Einstein's equation?
6. Under what conditions does the external photoelectric effect disappear?

II. Solve the problems

1. Formulate the laws of the photoelectric effect.
2. The threshold frequency of tungsten is 230 nm. Determine the kinetic energy of electrons emitted from tungsten by ultraviolet light with a wavelength of 150 nm.
3. Find the work function of the metal, if the photoeffect begins at the frequency $\nu_{\min} = 6 \cdot 10^{14} \text{ Hz}.$

4. Determine the threshold frequency for zinc and the maximum velocity of photoelectrons ejected from the surface of zinc by light with a wavelength of 200 nm. The work function for zinc is 3.74 eV. (1 eV = $1.6 \cdot 10^{-19}$ J).

5. The photoeffect stops if the frequency of light is reduced three times. Match the physical quantity (number) and the formula (letter).

1. The work function of the electron	a) $2h\nu/3$
2. Maximum kinetic energy of electrons	b) $\sqrt{4m h\nu/3}$
3. The minimum momentum of photons that cause the photoelectric effect	c) $\sqrt{4h\nu/3m}$
4. The momentum of the knocked-out electron	d) $h\nu / 3$
	e) $h\nu / 3c$

SECTION II

ATOMIC AND NUCLEAR PHYSICS

CHAPTER 4

Atomic physics

§ 12. Atomic Structure. Bohr's postulates

Atomic physics is a field of physics that studies the atomic structures and their interaction, the electron shell structure, and the radiation or absorption of energy by atoms.

1. Rutherford Atom Structure Model

In 1911, English physicist Ernest Rutherford proposed a **"planetary model" of the atom**. In this model, an atom consists of a central nucleus, in which almost all the mass and positive charge of the atom are concentrated. Electrons move around the nucleus in circular orbits, like planets around the Sun (Fig. 4.1). These orbits are known as **electron orbits, energy shells** or **energy levels**. The distribution of electrons in an atom is called an **electronic configuration**.

The planetary model of the atom contradicts several of experimental facts. It does not explain the emission and absorption of electromagnetic waves by atoms. According to classical theory, an electron orbiting an atom must emit electromagnetic waves continually. That would make the electron lose its energy and fall on the nucleus in 10^{-8} s causing the atom to collapse. But the atoms are stable. It means that the electrons in atoms move under some different laws contrary to classical mechanics and classical electrodynamics.

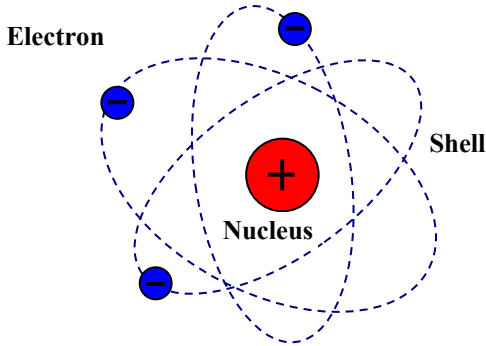

Fig. 4.1

2. Bohr's postulates

In 1923, the Danish physicist Niels Bohr proposed **two postulates** to explain the stability of the planetary model of the atom.

1. An atom is characterized by completely stable (**stationary**) states with corresponding values of energy $E_1, E_2, \dots E_n$, in which the atom does not absorb or emit electromagnetic waves. This means that the electrons can **only occupy certain definite orbits and cannot exist "in-between"**. For the allowed orbits, the angular momentum of an electron mVr must be a multiple of the value $\frac{h}{2\pi}$:

$$mVr = n \frac{h}{2\pi} = n\hbar ;$$

where m, V, r – are the mass, velocity and orbital radius of the electron, respectively; h – Planck constant; $\hbar = \frac{h}{2\pi}$ – reduced Planck constant, $n = 1, 2, 3 \dots$

2. During the transition from one steady-state to another, the atom emits or absorbs an electromagnetic wave (the discrete packets of electromagnetic wave are called photons), the frequency of which is determined by the following condition $E_i - E_j = h\nu$, where ν – is

the frequency; E_i – the initial energy of the atom; E_j – the energy of the atom after emission (or absorption); $i, j = 1, 2, 3, \dots$. If $i > j$, the quantum is emitted. If $i < j$, the quantum is absorbed. In this case $E_1 < E_2 < \dots < E_n$ (Fig. 4.2).

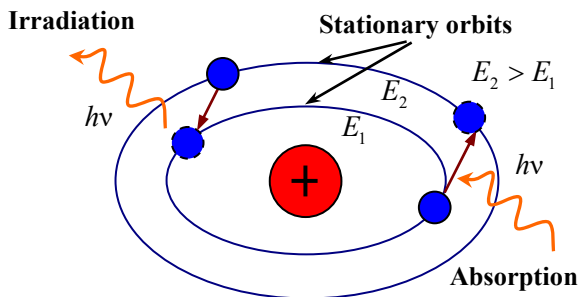

Fig. 4.2

Bohr's theory allows to calculate:

- the stationary orbits of the hydrogen atom and their energy levels;
- all the electron transitions from one orbit to another and the corresponding frequencies of quanta radiation.

3. Fingerprints of the Elements: Atomic Spectra

The emission spectrum is a set of electromagnetic waves emitted by the body. **The absorption spectrum** is the fraction of incident radiation absorbed by the atom over a range of frequencies. It reveals the dependence of the absorption coefficient on the irradiation frequency. The nature of atomic spectra is explained by quantum theory. When an atom passes from one steady-state to another, emission or absorption of a quantum of light (photon) occurs. Depending on the aggregate state of matter and its molecular structure, the emission spectra can be **linear**, **band** and **continuous**.

Linear spectra consist of sharp and well-defined spectral lines. Each line corresponds to an electromagnetic wave of a definite wavelength (and corresponding frequency). Such spectra are

characteristic of gases in which the molecules are dissociated into individual atoms or ions.

Therefore, the linear spectra correspond to the emission of noninteracting atoms. **The practical application** of linear spectra is based on the fact that each chemical element has its own characteristic set of wavelengths of emission spectral lines (Fig. 4.3 and 4.4). Therefore, a linear spectrum helps to identify the presence of each chemical element in any substance.

The linear spectrum of hydrogen H



Fig. 4.3

Band spectra are formed by the emission of molecules and consist of separate bright bands. Each band is found to be made of a large number of closely spaced lines. Using band spectra, the molecular structure of the substance can be studied.

A striped spectrum of iron Fe

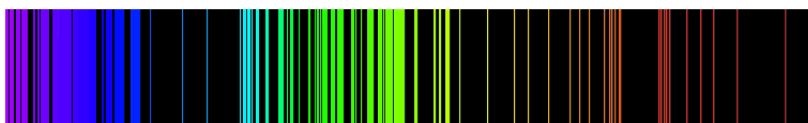

Fig. 4.4

Continuous spectra are emitted from heated solids and liquids. They are characterized by a continuous distribution of electromagnetic wave energy over a wide frequency range. The lines in the visible part of the atomic hydrogen spectrum were discovered in 1885 by Balmer. It is well known that Bohr's theory brilliantly describes the patterns in the spectrum of the hydrogen atom. But the hydrogen atom is the only one for which Bohr's theory gives good coincidence. Applying this theory to the helium (He) and further

atoms from Mendeleev's periodic table does not even match the experimental results qualitatively.

Further research has revealed that the idea of the discrete energy levels in atoms requires a completely different mathematical apparatus that was developed later in **quantum mechanics** (in 1926–1927).

Classical mechanics describes the state of a particle using its coordinate and velocity at a given point in time. Quantum mechanics describes the state of a particle by **the probability** of its presence at a certain point in time in a certain part of space.

Problem. What is the radius of the first electron Bohr orbit? ($n = 1$).

Solution. Between the nucleus and the electron there is a Coulomb force, which plays the role of centripetal force:

$$\frac{e^2}{4\pi\epsilon_0 r^2} = \frac{mV^2}{r} \Rightarrow \frac{e^2}{4\pi\epsilon_0} = mV^2 r.$$

According to Bohr's first postulate $mVr = n \frac{h}{2\pi}$. Multiplying both

sides of equation $\frac{e^2}{4\pi\epsilon_0} = mV^2 r$ by mr we obtain

$$\frac{e^2 mr}{4\pi\epsilon_0} = m^2 V^2 r^2, \quad \frac{e^2 mr}{4\pi\epsilon_0} = n^2 \frac{h^2}{4\pi^2}.$$

Finally, $r = \frac{n^2 h^2 \epsilon_0}{\pi^2 e^2 m} \approx 0.53 \cdot 10^{-10} \text{ m}.$

Answer: $r \approx 0.53 \cdot 10^{-10} \text{ m}.$

Words and phrases

planetary model	continuous spectrum	electron shell	striped spectra
stationary orbit	quantum mechanics	spectra of atoms	energy levels
spectral lines	nucleus	line spectrum	probability

Tasks for independent work

I. Answer the questions

1. What does atomic physics study?
2. What is the planetary model of the atom?
3. What is the electronic shell of the atom?
4. What are atomic spectra?
5. What is the nature of the atomic spectra?
6. What are the types of spectra?
7. What are linear spectra?
8. What is the practical application of linear spectra?

II. Perform exercises

1. Formulate Bohr's postulates.
2. Find the velocity of the electron in the first Bohr orbit ($n = 1$).
3. Find the electric field strength of the nucleus in the first Bohr orbit ($n = 1$).

Remember!

1. Linear spectra are added from individual narrow spectral lines.
2. Bohr's theory describes patterns in the spectrum of the hydrogen atom.

CHAPTER 5

Nuclear physics

§ 13. The structure of the atomic nucleus. Isotopes

1. The structure of the nucleus

Nuclear physics studies the structure and transformation of atomic nuclei by irradiating atoms with fast-moving particles. All atomic nuclei contain two types of elementary particles: protons and neutrons.

The proton p is a subatomic particle that has a positive charge equal to the charge of electron $|e| = 1,6 \cdot 10^{-19} \text{ C}$ and has the rest mass equal to $m_p = 1.6726 \cdot 10^{-27} \text{ kg}$.

Neutron n is a subatomic particle that has a neutral (not positive or negative) charge, and its mass is equal to $m_n = 1.6749 \cdot 10^{-27} \text{ kg}$. The common name of both these particles is **nucleons**.

The mass of nuclei and elementary particles is usually determined in the non-SI unit named as an atomic mass unit (amu):

$$m_p \approx m_n \approx 1 \text{ amu} = 1.66 \cdot 10^{-27} \text{ kg}.$$

The number of protons determines the magnitude of the nucleus charge Z . The sum of protons and neutrons in the nucleus is equal to the mass number:

$$A = Z + N_n,$$

where A – is the mass number; Z is the number of protons; N_n – the number of neutrons. Atomic nuclei are denoted by a symbol ${}_Z^A X$, where X – is the symbol of a chemical element. For example, ${}_{12}^{12}\text{C}$ means a carbon nucleus consisting of 6 protons and 6 neutrons, $A = 12$.

The nuclei of a chemical element that have the same charge number but different mass numbers are called **isotopes** of the

chemical element. Isotopes of a chemical element differ by the number of neutrons in the nucleus. For example, two isotopes of the chemical element hydrogen ${}^1_1\text{H}$ have their names: deuterium – ${}^2_1\text{H}$ and tritium – ${}^3_1\text{H}$. There is nuclear interaction between nucleons due to the **nuclear forces**. These forces begin to act at distances of $10^{-15} - 10^{-14}$ m. Nuclear forces are about 100 times greater than the forces of electrostatic interaction between the protons.

It is theoretically proven that a neutron and a proton can transform into each other. A neutron is converted into a proton, emitting an electron and a neutrino ν :

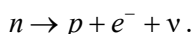

And vice versa, the proton can theoretically be converted into a neutron, emitting a positron and an antineutrino $\bar{\nu}$: $p \rightarrow n + e^{+} + \bar{\nu}$.

The average lifetime of a free neutron is 12.5 minutes. The free proton is more stable, its lifetime is $2.9 \cdot 10^{29}$ years. Protons, neutrons, electrons, positrons, neutrinos, antineutrinos, photons, and some other particles that can not fall apart into other particles are called **elementary particles**, or **fundamental particles**.

2. The phenomenon of radioactivity

Natural radioactivity is spontaneous fission, which happens when a large unstable nucleus spontaneously splits into two (or even three) smaller daughter nuclei, and generally leads to the emission of gamma rays, neutrons, or other particles from those products. This transformation of nuclei is called **radioactive decay**. The decay of the nucleus is divided into three types depending on the particles formed as a result of radioactive decay. Natural radioactivity may be accompanied by the appearance of one of the types of radiation, α, β, γ or which have different ionizing and permeable abilities to interact with the substance.

Ionizing ability is the ability of radiation to knock electrons out of atoms of matter and form ions.

Permeability is the depth of the ionizing effect of radiation. Rutherford found that α -, β - and γ -beams have different trajectories in a constant magnetic field (Fig. 5.1).

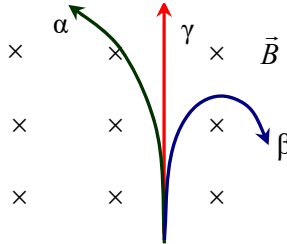

Fig. 5.1

Alpha rays (α -rays) are a stream of nuclei of helium atoms (${}^4_2\text{He}$). Each α -particle has a charge of $+2e$ and $A = 4$. Generally, α -rays fly out from the nucleus at a speed from 14,000 up to 20,000 km/s. Alpha rays have high ionizing power and low permeability. One α -particle with an energy of 3 MeV can ionize 100,000 gas atoms or up to a million atoms in a crystal. Alpha rays are completely absorbed by a 0.12 mm thick layer of biological tissue.

Beta rays (β -rays) are a stream of electrons at a speed of 160,000 km/s. Permeability of this type of particles in the air is 40 m, in aluminium – 2 cm, in biological tissue – 6 cm.

Gamma rays are the rays of photons. Gamma rays have a frequency of 10^{20} Hz and an energy of 1 MeV. They penetrate through the human body.

In the alpha decay process, the charge of the nucleus decreases in two units, and the mass number decreases in four units:

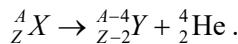

In the beta decay process, the charge of the nucleus increases by one, and the element is shifted in the periodic table by one number to the right without changing the mass number

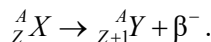

The appearance of gamma rays can be described by the following reaction:

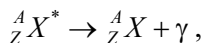

where ${}^A_Z X^*$ indicates an excited nuclear state (a state with excess energy). Equivalent nuclei with differing energies are called nuclear isomers.

3. The law of radioactive decay. Half-life

Radioactive decay reduces the number of atoms of a radioactive element. It is a random process, so we can only talk about the probability of decay of each atom for a certain period. The number of atoms that decay over time is proportional to the time and the total number of atoms (N) of the radioactive element

$$\frac{\Delta N}{\Delta t} = -\lambda N,$$

where λ – **decay constant (decay rate)**. The decay constant is equal to the relative decrease in the number of atoms per unit of time

$$\lambda = -\frac{\Delta N}{N\Delta t}.$$

The minus sign indicates the number of atoms decreasing over time.

The law of radioactive decay has the form $N = N_0 e^{-\lambda t}$, where N_0 – is the number of radioactive atoms at the initial moment; N – the number of atoms remaining for time, number $e \approx 2.72$. Graphically, the law of radioactive decay is presented in Fig. 5.2. As a result of radioactive decay, a substance with new physical and chemical properties is formed. To characterize the decay rate of a radioactive element, the concept of the half-life T is introduced.

The half-life is the time taken for the activity of a given amount of a radioactive substance to decay to half of its initial value. The half-life is equal to

$$T = \frac{\ln 2}{\lambda} = \frac{0.693}{\lambda}.$$

The values of T and λ are different for different radioactive elements. For example, for uranium $^{239}_{92}\text{U}$ the value of the half-life is $4.5 \cdot 10^9$ years, for radium – 1622 years.

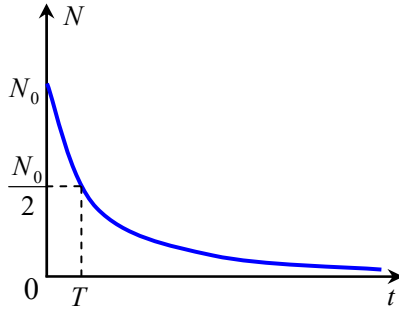

Fig. 5.2

Problem. Determine the half-life of radon, if 175,000 atoms decay from 1 million atoms in one day.

Given:

$$N_0 = 10^6$$

$$\Delta N = 1.75 \cdot 10^5$$

$$t = 24 \cdot 60 \cdot 60 = 86400 \text{ s}$$

Find: T -?

Solution. The half-life is equal to $T = \frac{\ln 2}{\lambda} = \frac{0.693}{\lambda}$. Let's find the constant decay

$$\Delta N = N_0 - N = N_0 - N_0 e^{-\lambda t} = N_0 (1 - e^{-\lambda t});$$

$$\frac{\Delta N}{N_0} = (1 - e^{-\lambda t}).$$

Logarithm the left and right parts of the equation $1 - \frac{\Delta N}{N_0} = e^{-\lambda t}$:

$$\ln \left(1 - \frac{\Delta N}{N_0} \right) = \ln(e^{-\lambda t}) \Rightarrow \ln \left(1 - \frac{\Delta N}{N_0} \right) = -\lambda t,$$

$$\lambda = -\frac{\ln\left(1 - \frac{\Delta N}{N_0}\right)}{t} = \frac{\ln\left(1 - \frac{\Delta N}{N_0}\right)^{-1}}{t} = \frac{\ln\frac{N_0}{N_0 - \Delta N}}{t}.$$

The half-life of radon is equal to

$$T = \frac{\ln 2}{\lambda} = \frac{0.693}{\lambda} = \frac{0.693t}{\ln\frac{N_0}{N_0 - \Delta N}},$$

$$T = -\frac{0.693 \cdot 86400 \text{ c}}{\ln(10^6 / (10^6 - 1.75 \cdot 10^5))} = \frac{0.693 \cdot 86400 \text{ c}}{\ln(10^6 / 8.25 \cdot 10^5)} =$$

$$= \frac{59875.2}{0.192} \text{ c} = 3.1 \cdot 10^5 \text{ s}.$$

Answer: $T = 3.1 \cdot 10^5 \text{ s} \approx 3.5 \text{ days}.$

Words and phrases

nucleus	proton	mass number	nucleon
radioactivity	alpha rays (α)	elementary particle	symbol
natural radioactivity	beta rays (β)	decay	decay constant
neutron	gamma rays (γ)	half-life	decay rate

Tasks for independent work

I. Answer the questions

1. What does nuclear physics study?
2. What particles form the nucleus of an atom?
3. What is called a mass number?
4. What is the difference between the isotopes of one chemical element?
5. What is called radioactivity?
6. What are the α -, β -, γ -rays?
7. What is called the half-life?

II. Perform exercises

1. Formulate the law of radioactive decay.
2. How many uranium nuclei ${}_{92}^{238}\text{U}$ decay during the year, if the initial mass of uranium is 1 g? The half-life of uranium ${}_{92}^{238}\text{U}$ is $4.51 \cdot 10^9$ years.
3. The half-life of radioactive phosphorus ${}_{15}^{30}\text{P}$ is 30 minutes. Find is the constant decay of these nuclei.

Remember!

1. Radioactive decay reduces the number of atoms of a radioactive element.
2. The number of protons determines the magnitude of the charge of the nucleus Z.

§ 14. Nuclear reactions. Artificial radioactivity

1. Nuclear reactions

The study of natural radioactivity has shown that this is a phenomenon due to intranuclear processes. This discovery led scientists to implement the artificial transformation of some chemical elements into others.

A **nuclear reaction** is a process of transformation of atomic nuclei under the influence of fast elementary particles or nuclei of other atoms. The first artificial nuclear reaction was carried out by the English scientist Ernest Rutherford in 1919. It can be written as

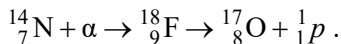

This reaction proceeds as follows: the α -particle enters the nitrogen nucleus ${}_{7}^{14}\text{N}$ and is absorbed by it. An intermediate nucleus of the fluorine isotope ${}_{9}^{18}\text{F}$ is formed, which emits one proton ${}_{1}^{1}p$ and turns into the nucleus of the oxygen isotope ${}_{8}^{17}\text{O}$.

In 1932, the English physicist James Chadwick discovered a **neutron** as a result of a nuclear reaction. The half-life of a free neutron is about 10 minutes. The phenomenon of **artificial radioactivity** was discovered in 1934 by French physicists Irene and Frédéric Joliot Curie in the study of the reaction of irradiation of aluminium nuclei with α -particles:

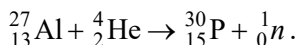

As a result, they obtained a radioactive artificial isotope of phosphorus ${}_{15}^{30}\text{P}$.

Due to nuclear reactions, the periodic table is updated by discovering new artificial chemical elements with a nuclear charge that exceeds the charge of the uranium nucleus. Such chemical elements are called **transuranic elements** (for example, neptunium, plutonium, americium).

2. The binding energy of the nucleus. Mass defect

Binding energy is one of the most important quantities that characterize the stability of the atomic nucleus. **The binding energy of the nucleus** is the energy required for the complete splitting of the nucleus into nucleons that are part of it. According to the law of conservation of energy, the energy of the nucleons that are bound in the nucleus must be less than the energy of the separated nucleons by the value of the binding energy of the nucleus ε_b . According to the law of proportionality of mass and energy, the change in the energy of the system is accompanied by a proportional change in the mass of the system $\varepsilon_b = \Delta mc^2$, where c is the speed of light in a vacuum. The mass of an atomic nucleus is less than the sum of the masses of the nucleons that make up the nucleus by an amount Δm (the nuclear mass defect).

The **mass defect** is determined by the difference between the mass of individual nucleons before merging them into a nucleus with the mass m_N formed as a result of this reaction:

$$\Delta m = [Zm_p + (A - Z)m_n] - m_N,$$

where Z – atomic number, A – mass number, m_p – proton mass, m_n – neutron mass. The presence of a mass defect leads to the fact that the combination of individual nucleons in the nucleus releases energy equal to the binding energy

$$\varepsilon_b = c^2 \left(\left[Zm_p + (A - Z)m_n \right] - m_N \right).$$

The release of nuclear energy occurs both in the fission reaction of heavy nuclei and in the fusion reaction of light nuclei. The nuclear energy released by each nucleus is equal to the difference between the binding energy of the reaction product and the binding energy of the nuclear source material $\Delta\varepsilon_b = \varepsilon_{b_2} - \varepsilon_{b_1}$, where ε_{b_2} – the binding energy of the reaction product; ε_{b_1} – binding energy of the source product.

The magnitude of the binding energy depends on the nucleus of the chemical element. For example, for an isotope ${}^7_3\text{Li}$, the binding energy is $\varepsilon_b = 6.291 \cdot 10^{-12}$ J per one atom, then a 1 mol of ${}^7_3\text{Li}$ will have a huge total binding energy

$$E = N_A \cdot \varepsilon_b = 6.02 \cdot 10^{23} \cdot 6.291 \cdot 10^{-12} \text{ J} = 3.787 \cdot 10^{12} \text{ J},$$

where N_A – is the Avogadro number.

The binding energy released during a nuclear reaction makes it possible to obtain a large amount of nuclear energy and convert it into other types of energy – thermal and electrical. Nuclear power plants operate based on these principles and laws.

Problem 1. Calculate the mass defect of the nucleus of the neon isotope ${}^{20}_{10}\text{Ne}$.

Solution. By definition, the defect in the mass of the nucleus is equal to

$$\Delta m = \left[Zm_p + (A - Z)m_n \right] - m_N.$$

For neon: ${}^{20}_{10}\text{Ne}$:

$$Z = 10, A = 20, \text{ thus } \Delta m = \left[10m_p + 10m_n \right] - m_N,$$

$$m_p = 1.6726 \cdot 10^{-27} \text{ kg},$$

$$m_n = 1.6749 \cdot 10^{-27} \text{ kg},$$

$$m_N = 33.1888 \cdot 10^{-27} \text{ kg};$$

$$\begin{aligned} \Delta m &= [1.6726 + 1.6749] \cdot 10^{-26} \text{ kg} - 33.1888 \cdot 10^{-27} \text{ kg} = \\ &= 0.2762 \cdot 10^{-27} \text{ kg}. \end{aligned}$$

$$\text{Answer: } \Delta m = 2.762 \cdot 10^{-28} \text{ kg}.$$

Problem 2. Find the binding energy of the lithium isotope nucleus ${}^7_3\text{Li}$.

Solution. The binding energy of the nucleus is equal to $\varepsilon_b = \Delta mc^2$. We calculate $\varepsilon_b = c^2 \left([Zm_p + (A-Z)m_n] - m_N \right)$:

$$\varepsilon_b = c^2 \left([3m_p + (7-3)m_n] - m_N \right);$$

$$\begin{aligned} \varepsilon_b &= \left(3 \cdot 10^8 \frac{\text{m}}{\text{s}} \right)^2 \left[(3 \cdot 1.6726 + 4 \cdot 1.6749) \cdot 10^{-27} \text{ kg} - 11.6475 \cdot 10^{-27} \text{ kg} \right] = \\ &= 9 \cdot 10^{16} \cdot 0.0699 \cdot 10^{-27} \text{ J} = 6.291 \cdot 10^{-12} \text{ J}. \end{aligned}$$

$$\text{Answer: } \varepsilon_b = 6.291 \cdot 10^{-12} \text{ J}.$$

Problem 3. A nucleus of a nitrogen isotope ${}^{14}_7\text{N}$ captures an α -particle. As a result, an unknown element and a proton were formed. Record the reaction and identify the unknown element.

Solution. Let's write the equation of the nuclear reaction

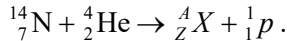

According to the laws of conservation of mass and charge, the sums of mass numbers and charges in the right and left parts of the reaction equation should be equal to each other:

$$14 + 4 = A + 1 \Rightarrow A = 17;$$

$$7 + 2 = Z + 1 \Rightarrow Z = 8.$$

A chemical element that has a charge number of 8 is the nucleus of oxygen. Therefore, an isotope $^{17}_8\text{O}$ is formed as a result of a nuclear reaction.

Answer: oxygen isotope $^{17}_8\text{O}$.

Words and phrases

nuclear reaction	mass defect	intermediate nucleus	fusion reaction
binding energy	artificial radioactivity	easy nucleus	transuranic elements
artificial	hard nucleus	exposure	the reaction product

Tasks for independent work

I. Answer the questions

1. What is called a nuclear reaction?
2. What is artificial radioactivity?
3. When was the phenomenon of artificial radioactivity discovered?
4. What are the transuranic elements? Give some examples of transuranic elements.
5. What is a radioactive isotope?
6. What is a core mass defect?
7. What is called the binding energy of the nucleus?

II. Perform exercises

1. Write equations for the defect of the mass and binding energy of the nucleus.
2. Due to radioactive decay, uranium $^{238}_{92}\text{U}$ is converted to lead $^{208}_{82}\text{Pb}$ with the formation of α - and β -rays. Determine the number of α - and β -particles.
3. Due to the capture of a neutron by the nucleus of a nitrogen atom $^{14}_7\text{N}$, an unknown isotope and α -particle were formed. Record the reaction and determine the isotope formed.
4. Find the binding energy of the uranium nucleus $^{238}_{92}\text{U}$ and the binding energy per one nucleon.

§ 15. Nuclear reactor. Thermonuclear fusion

1. Nuclear chain reactions

Nuclear chain reactions refer to a process in which neutrons released in fission produce additional fission in at least one further nucleus. This nucleus in turn produces neutrons, and the process repeats. The process may be controlled (nuclear power) or uncontrolled (nuclear weapons). The nuclear chain reaction releases several million times more energy per reaction than any chemical reaction. The simplest chain reaction occurs in a substance whose nuclei fission under the action of slow neutrons, for example, in the isotope uranium-235 (${}^{235}_{92}\text{U}$) (Fig. 5.3).

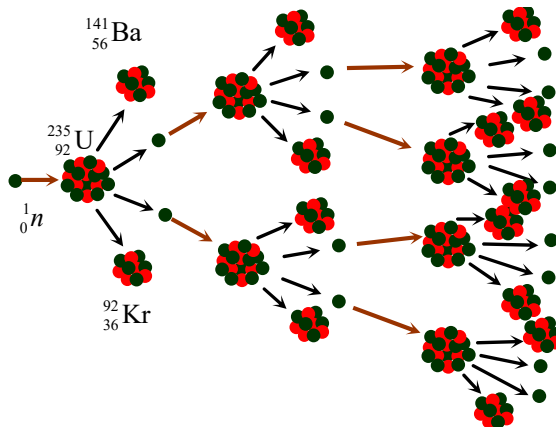

Fig. 5.3

If one of the neutrons enters the nucleus ${}^{235}_{92}\text{U}$, the nucleus splits into two fragments ${}^{141}_{56}\text{Ba}$ and ${}^{92}_{36}\text{Kr}$ with a formation of two neutrons. These neutrons fall into two new nuclei, and the split process repeats. This process produces four neutrons, which cause the fission of four nuclei. As a result, eight neutrons will be released, etc.

Thus, a fission chain reaction is formed. The development of the chain reaction is characterized by the neutron multiplication factor K .

The neutron multiplication factor K is determined by the ratio of the number of neutrons in the reaction step to the number of neutrons in the previous one. An example of a chain reaction in our case is the multiplication factor:

$$K = \frac{4}{2} = \frac{8}{4} = 2.$$

The mass of the substance in which the chain reaction begins $K = 1$ is called the **critical mass**. A necessary condition for the development of a chain reaction is a condition $K \geq 1$.

Example. For a pure isotope ${}_{92}^{235}\text{U}$, the critical mass is about 40 kg of spherical matter. If the mass of nuclear material is less than critical $K < 1$, then the reaction the division will go out. If $K > 1$, then the chain reaction will develop rapidly, which can lead to an explosion. This reaction occurs in an **atomic bomb**. If $K = 1$, the reaction occurs at a constant intensity.

2. Nuclear reactor

A **nuclear reactor** is a device designed to produce a controlled self-sustaining fission chain reaction that is accompanied by the release of energy. **The main elements of a nuclear reactor:** nuclear fuel, moderator and neutron reflector, coolant for heat dissipation generated in the reactor, regulators of the fission chain reaction rate.

Nuclear fuels are the isotopes: uranium ${}_{92}^{235}\text{U}$ and ${}_{92}^{238}\text{U}$, plutonium ${}_{94}^{239}\text{Pu}$, thorium ${}_{90}^{232}\text{Th}$.

Inhibitors and neutron reflectors increase the number of slow neutrons to support the fission chain reaction. To maintain the steady state of the reactor ($K = 1$), boron or cadmium rods are inserted into the reactor to strongly absorb thermal neutrons and make it possible to control the development of the chain reaction. The heat carriers in the reactor are water or liquid sodium. Along with the release of energy in a nuclear reactor is the formation and accumulation

of a new nuclear fuel – plutonium ${}_{94}^{239}\text{Pu}$. Plutonium is radioactive, it emits α -, β - and γ -rays. Its half-life is $T = 2.4 \cdot 10^4$ years.

Nuclear energy is the energy released during the nuclear fission chain reactions of heavy nuclei. Nuclear energy is used in **nuclear power plants**.

3. Thermonuclear reactions

Thermonuclear reactions are called exothermic nuclear reactions of synthesis of light nuclei into heavier ones. These reactions occur at extremely high temperatures. During thermonuclear reactions, a very large amount of energy is released. In the fusion reaction of deuterium ${}^2_1\text{H}$ and tritium nuclei ${}^3_1\text{H}$ into the helium ${}^4_2\text{He}$, energy of 3.5 MeV per 1 nucleon is released, and the total energy released as a result of the reaction is 17.6 MeV:

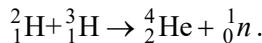

In the fission reaction, the energy per 1 nucleon is approximately 1 MeV ($1\text{MeV} = 10^6 \text{eV}$, $1\text{eV} = 1.6 \cdot 10^{-19} \text{J}$). For example, the synthesis of a helium nucleus from four protons releases the energy equal to 6.7 MeV per one particle:

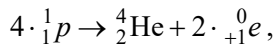

where ${}^0_{+1}e$ or e^+ is the symbol of the positron (the antiparticle of the electron).

Thermonuclear reactions take place inside the Sun and the stars, and they are a source of energy, which provides their radiation. The implementation of thermonuclear reactions in terrestrial conditions will create huge opportunities for energy production. For example, when using deuterium from 1 litre of ordinary water, the fusion reaction will release as much energy as is released during the combustion of 350 litres of gasoline.

In a hydrogen bomb, the thermonuclear reaction is uncontrolled. To carry out a controlled thermonuclear reaction, it is necessary to create and maintain in a certain volume at a temperature of $\approx 10^8 \text{K}$.

This is necessary to bring the nuclei of the elements together, overcoming the enormous Coulomb forces of repulsion. At this high temperature, "thermonuclear fuel" becomes to be a plasma.

Plasma is one of the four fundamental states of matter, an ionized gas consisting of electrons and nuclei. The plasma is held by a magnetic field, and its high temperature is obtained by passing high electric currents through it. Preservation of plasma stability is a major problem in the implementation of a controlled thermonuclear reaction.

Problem. What amount of energy is released as a result of the fusion reaction of the synthesis of 1 g of helium from deuterium and tritium?

Solution. Equation of thermonuclear reaction of synthesis of deuterium and tritium nuclei

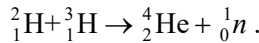

The amount of energy released in this case, $\Delta E = \Delta mc^2$. The mass defect is equal to

$$\begin{aligned}\Delta m &= \left(m_{{}^2_1\text{H}} + m_{{}^3_1\text{H}}\right) - \left(m_{{}^4_2\text{He}} + m_{{}^1_0n}\right), \\ \Delta m &= (2.01410 + 3.01605) \text{ amu} - (4.00260 + 1.00866) \text{ amu} = \\ &= 0.01889 \text{ amu}, \text{ where } 1 \text{ amu} \approx 1.66 \cdot 10^{-27} \text{ kg}.\end{aligned}$$

Taking into account the equivalence of mass and energy

$$\begin{aligned}E = mc^2 &= 1 \text{ amu} \cdot s^2 = 1,66 \cdot 10^{-27} \text{ kg} \cdot s^2 = 1.66 \cdot 10^{-27} \cdot 9 \cdot 10^{16} \text{ J} = \\ &= 1.494 \cdot 10^{-10} \text{ J} = \frac{1.494 \cdot 10^{-10} \text{ J}}{1.6 \cdot 10^{-19} \frac{\text{J}}{\text{eV}}} \text{ eV} = 9.33 \cdot 10^8 \text{ eV} = 933 \text{ MeV}.\end{aligned}$$

From here $1 \text{ amu} \approx 933 \frac{\text{MeV}}{s^2}$. Then the energy released during the

synthesis of one helium nucleus ${}^4_2\text{He}$ is equal to

$$\begin{aligned}\Delta E = \Delta mc^2 &= 0.01889 \text{ amu} \cdot s^2 = \\ &= 0.01889 \cdot 933 \frac{\text{MeV}}{s^2} \cdot s^2 = 17.6 \text{ MeV}.\end{aligned}$$

The energy released during the synthesis of 1 g of helium

$$E = \Delta E \cdot N = \Delta E \cdot N_A \cdot \frac{m}{M_{\text{He}}},$$

where m – is the mass of synthesized helium, N – is a number of nuclei in grams of helium, $N_A = 6.02 \cdot 10^{23} \text{ mol}^{-1}$ – is the Avogadro's number, $M_{\text{He}} = 4 \text{ g} \cdot \text{mol}^{-1}$ – is a molar mass of helium:

$$E = \Delta E \cdot \frac{N_A \cdot m}{M_{\text{He}}} = 17.6 \text{ MeV} \cdot \frac{6.02 \cdot 10^{23} \text{ mol}^{-1} \cdot 1 \text{ g}}{4.0 \text{ g} \cdot \text{mol}^{-1}} =$$

$$= 2.65 \cdot 10^{24} \text{ MeV} = 2.65 \cdot 10^{24} \text{ MeV} \cdot 1.6 \cdot 10^{-19} \frac{\text{J}}{\text{MeV}} = 4.24 \cdot 10^5 \text{ J}.$$

Answer: $E = 4.24 \cdot 10^5 \text{ J} = 0.424 \text{ MJ}$.

Words and phrases

chain reaction	explosion	reflector	atomic bomb
neutron	nuclear reactor	rod	nuclear bomb
critical mass	moderator	nuclear energy	nuclear warhead
multiplication factor	heat-carrier	nuclear energy fusion	thermonuclear reaction

Tasks for independent work

I. Answer the questions

1. What is a chain reaction?
2. How to determine the multiplication factor of neutrons?
3. What is critical mass?
4. What is called a nuclear reactor?
5. What are the main elements of the reactor?
6. What isotopes are the fuel for a nuclear reaction?
7. What are thermonuclear reactions?
8. Why the ultra-high plasma temperature is the condition for a thermonuclear reaction?

9. Why the synthesis of light nuclei is more energetically advantageous than the fission reaction of heavy nuclei?

II. Perform exercises

1. Write the reaction of helium nucleus synthesis from deuterium and tritium isotopes.

2. The half-life of potassium-42 is 12 hours. How much energy does a tablet containing 10 mg of potassium release per 1 day if 5 MeV of energy is released during the decay of each nucleus?

3. Half-lives of two radioactive substances are equal to T and $4T$, respectively. The mass of the first substance is 8 times greater than the mass of the second one. At what time the masses of both substances will be equalized?

4. Helium is formed during the explosion of a hydrogen bomb from deuterium and tritium. Determine the energy released during the formation of 10 g of helium.

LITERATURE

1. Навчальні програми (довузівська підготовка іноземних громадян) / уклад. : Б. М. Андрюшенко, Ю. М. Івашенко, Ю. О. Колтаков та ін. – К. : ІВЦ вид-во "Політехніка", 2005. – Ч. 2. Фізика. – 168 с. (in Ukrainian).

2. Фізика для студентів-іноземців : навч. посіб. / О. О. Каленик, І. В. Плющай, Т. Л. Цареградська. – К. : ВПЦ "Київський університет", 2021. – 295 с. (in Ukrainian).

3. Каленик О. О., Корочкіна Л. М. Фізика для студентів-іноземців : навч. посіб. / О. О. Каленик, Л. М. Корочкіна. – К. : "Інтерсервіс", 2013. – 194 с. (in Ukrainian).

4. Каленик О. О., Цареградська Т. Л. Практичні заняття з фізики (електрика, оптика, атомна та ядерна фізика) для студентів-іноземців підготовчих відділень / О. О. Каленик, Т. Л. Цареградська. – К. : "Інтерсервіс", 2017. – 134 с. (in Ukrainian).

5. SAT. Subject test. Physics / Ed. M. A. Robert Jansen, M. S. Greg Young. – N.Y. : Barron's Educational Series, Inc., 2013. – 589 p.

6. Фізика. Комплексна підготовка до зовнішнього незалежного оцінювання / уклад. : Н. Струж, В. Мацюк, С. Остап'юк. – Тернопіль : Підручники і посібники, 2016. – 432 с. (in Ukrainian).

APPENDIX

1. Basic physical constants

Earth's radius	$R_E = 6.37 \cdot 10^6 \text{ m}$
Mass of the Earth	$M_E = 5.97 \cdot 10^{24} \text{ kg}$
Gravitational constant	$G = 6.67 \cdot 10^{-11} \text{ m}^3 / (\text{kg} \cdot \text{s}^2)$
Freefall acceleration	$g = 9.81 \text{ m/s}^2$
The Avogadro constant	$N_A = 6.023 \times 10^{23} \text{ mol}^{-1}$
The Boltzmann constant	$k = 1.38 \cdot 10^{-23} \text{ J} \cdot \text{K}^{-1}$
The molar gas constant	$R = 8.31 \text{ J} \cdot \text{mol}^{-1} \cdot \text{K}^{-1}$
The standard volume of 1 mole of gas	$V_0 = 22.41 / \text{mol}$
Elementary charge	$e = 1.602 \cdot 10^{-19} \text{ C}$
Electric constant	$\epsilon_0 = 8.85 \cdot 10^{-12} \text{ F/m}$
Vacuum permeability	$\mu_0 = 1.257 \cdot 10^{-6} \text{ H/m}$
Speed of light in vacuum	$c = 2.998 \cdot 10^8 \text{ m/s}$
Electron mass	$m_e = 9.11 \cdot 10^{-31} \text{ kg}$
Proton mass	$m_p = 1.6726 \cdot 10^{-27} \text{ kg}$
Neutron mass	$m_n = 1.6749 \cdot 10^{-27} \text{ kg}$
Planck constant	$h = 6.63 \cdot 10^{-34} \text{ J} \cdot \text{s}$
Reduced Planck constant	$\hbar = \frac{h}{2\pi} = 1.05 \cdot 10^{-34} \text{ J} \cdot \text{s}$
Atomic mass unit	$1 \text{ amu} = 1.66 \cdot 10^{-27} \text{ kg}$

2. Density of some substances

Solids, 10^3 kg/m^3			
Aluminium	2.7	Copper	8.9
Wood	0.8	Nickel	8.8
Iron	7.8	Lead	11.3
Brick	1.8	Silver	10.5
Ice	0.9	Steel	7.8
Liquids, 10^3 kg/m^3			
Pure water	1	Oil	0.9
Seawater	1.03	Mercury	13.6
Kerosene	0.8	Ethanol	0.8
Gases, kg/m^3			
Hydrogen	0.089	Helium	0.18
Air	1.29	Oxygen	1.43

3. The modulus of elasticity in tension (Young's modulus), 10^{11} Pa

Aluminium	0.7	Copper	1.2
Iron	2.1	Steel	2.2
Brass	0.9	Lead	0.17

4. Coefficient of surface tension of liquids (at room temperature), 10^{-2} N/m

Aniline	4.3	Soap solution	4
Water	7.4	Alcohol	2.2
Kerosene	3.6	Mercury	47.1

5. Specific heat capacity, $10^3 \text{ J/(kg}\cdot\text{K)}$

Nitrogen	1.05	Ice	2.1
Aluminium	0.88	Copper	0.39
Water	4.19	Tin	0.23
Hydrogen	14.2	Air	1.005
Iron	0.46	Lead	0.13
Oxygen	0.92	Ethanol	2.42
Brass	0.38	Steel	0.46

6. Melting point of solids, K

Aluminium	933	Copper	1356
Iron	1803	Tin	505
Brass	1173	Lead	600
Ice	273	Silver	1233

7. Specific heat of fusion solids, 10^5 J/kg

Aluminum	3.9	Tin	0.58
Ice	3.35	Lead	0.25
Copper	1.8	Silver	1.01

8. The temperature of vaporization, K

Water	373	Ethanol	351
Mercury	630	Ether	308

9. Specific heat of vaporization 10^5 J/kg

Water	22.6	Ethanol	9.05
Mercury	2.82	Ether	3.68

10. Specific heat of combustion, 10^7 J/kg

Petrol	4.61	Gas	4.61
Wood	1.26	Oil	4.61
Coal	2.93	Ethanol	2.93

11. Coefficient of linear expansion in solids, 10^{-5} K⁻¹

Aluminium	2.4	Copper	1.7
Iron	1.2	Lead	2.9
Invar	0.15	Steel	1.1
Brass	1.9	Glass	0.9

12. Coefficient of volumetric expansion in liquids, 10^{-4} K^{-1}

Water	1.8	Mercury	1.8
Kerosene	10.0	Sulfuric acid	5.6
Petroleum	10.0	Ethanol	11.0

Note. The values of physical quantities are given under normal conditions.

13. The relative permittivity

Dielectric	ϵ	Dielectric	ϵ
Water	81	Polyethene	2.3
Air	1.00058	Mica	7.0
Wax	7.8	Ethanol	26
Kerosene	2.0	Glass	6.0
Paraffin	2.0	Porcelain	6.0
Plexiglas	3.5	Ebonite	2.7

14. Specific resistance of conductors and insulators

Conductor	Specific electrical resistance (at 20 °C) $\rho, \text{nOhm}\cdot\text{m}$	Temperature coefficient $\alpha,$ 10^{-3} K^{-1}	Insulator	Specific electrical resistance $\rho, \text{Ohm m}$
Aluminium	25	4.5	Paper	10^{10}
Tungsten	50	4.8	Paraffin	10^{15}
Iron	90	6.5	Mica	10^{13}
Gold	20	4.0	Porcelain	10^{13}
Copper	16	4.3	Shellac	10^{14}
Lead	190	4.2	Ebonite	10^{14}
Silver	15	4.1	Amber	10^{17}

15. Refractive index n

Gas	n	Liquid	n	Solid	n
Nitrogen	1.00030	Benzene	1.50	Diamond	2.42
Air	1.00029	Water	1.33	Quartz	1.46
Oxygen	1.00027	Glycerin	1.47	Glass	1.50

Note. The refractive index depends on the length of light, so the given values of n should be considered conditional.

16. The work of the electron output from the metal

Metal	A , eB	Metal	A , eB
Aluminium	3.74	Copper	4.47
Barium	2.29	Molybdenum	4.27
Bismuth	4.62	Sodium	2.27
Tungsten	4.50	Nickel	4.84
Iron	4.36	Platinum	5.29
Gold	4.58	Silver	4.28
Potassium	2.15	Titanium	3.92
Cobalt	4.25	Caesium	1.89
Lithium	2.39	Zinc	3.74

17. Half-lives of radionuclides

Cobalt ^{60}Co	5.2 years (β)
Strontium ^{90}Sr	28 years (β)
Polonium ^{210}Po	138 days (α)
Radon ^{222}Rn	3.8 days (α)
Radium ^{226}Ra	1620 years (α)
Uranium ^{238}U	4.5 10 ⁹ years (α)

18. Some non-system units

1 Å	10 ⁻¹⁰ m
1 atm	101.3 kPa or 760 mm Hg
1 bar	100 kPa
1 mm Hg	133.3 Pa
1 cal	4.18 J

CONTENTS

Preface	3
----------------------	---

SECTION I

Electricity and magnetism. Optics

Chapter 1. Electricity	4
§ 1. Electrical charge. Coulomb's law	4
§ 2. Main characteristics of electric field	9
§ 3. Electric capacity. Electric field energy	19
§ 4. Electric current. Resistance. Ohm's law	25
§ 5. Laws of direct electric current	35
Chapter 2. Magnetism	42
§ 6. Magnetism. Magnetic induction vector	42
§ 7. Magnetic flux. Electromagnetic induction	49
§ 8. Alternating current. Electromagnetic waves	54
Chapter 3. Optics	61
§ 9. Geometric optics	61
§ 10. Wave optics	70
§ 11. Basic concepts of quantum optics	75

SECTION II

Atomic and nuclear physics

Chapter 4. Atomic physics	81
§ 12. Atomic Structure. Bohr's postulates	81
Chapter 5. Nuclear physics	87
§ 13. The structure of the atomic nucleus. Isotopes	87
§ 14. Nuclear reactions. Artificial radioactivity	93
§ 15. Nuclear reactor. Thermonuclear fusion	97
Literature	104
Appendix	105

Навчальне видання

КАЛЕНИК Олександр Олександрович
ПЛЮЩАЙ Інна В'ячеславівна
ЦАРЕГРАДСЬКА Тетяна Леонідівна
ЛІЩУК Павло Олександрович

ФІЗИКА
Електрика і магнетизм, оптика,
атомна та ядерна фізика

Навчальний посібник
(англійською мовою)

Друкується за авторською редакцією

Оригінал-макет виготовлено ВПЦ "Київський університет"

Виконавець Г. Пластуненко



Формат 60x84^{1/16}. Ум. друк. арк. 6,51. Наклад 100. Зам. № 222-10352.
Гарнітура Times New Roman. Папір офсетний. Друк офсетний. Вид. № П1.
Підписано до друку 04.04.22

Видавець і виготовлювач
ВПЦ "Київський університет"

Б-р Тараса Шевченка, 14, м. Київ, 01601, Україна
☎ (044) 239 32 22; (044) 239 31 72; тел./факс (044) 239 31 28
e-mail: vpc_div.chief@univ.net.ua; redaktor@univ.net.ua
http: vpc.knu.ua

Свідоцтво суб'єкта видавничої справи ДК № 1103 від 31.10.02